

Legal Provisions

No part of this document may be reproduced, stored in a retrieval system, or transmitted, in any form or by any means, be it electronic, mechanical, photographic, magnetic or otherwise, without the prior written permission of SMA Solar Technology America LLC.

Neither SMA Solar Technology America LLC nor SMA Solar Technology Canada Inc. makes representations, express or implied, with respect to this documentation or any of the equipment and/or software it may describe, including (with no limitation) any implied warranties of utility, merchantability, or fitness for any particular purpose. All such representations or warranties are expressly disclaimed. Neither SMA Solar Technology America LLC nor its distributors or dealers nor SMA Solar Technology Canada Inc. nor its distributors or dealers shall be liable for any indirect, incidental, or consequential damages under any circumstances.

The exclusion of implied warranties may not apply in all cases under some statutes, and thus the above exclusion may not apply.

Specifications are subject to change without notice. Every attempt has been made to make this document complete, accurate and up-to-date. Readers are cautioned, however, that product improvements and field usage experience may cause SMA Solar Technology America LLC and/or SMA Solar Technology Canada Inc. to make changes to these specifications without advance notice, or per contract provisions in those cases where a supply agreement requires advance notice. SMA shall not be responsible for any damages, including indirect, incidental or consequential damages, caused by reliance on the material presented, including, but not limited to, omissions, typographical errors, arithmetical errors or listing errors in the content material.

SMA Warranty

You can download the current warranty conditions from the Internet at www.SMA-Solar.com.

Software licenses

The licenses for the used software modules can be called up on the user interface of the product.

Trademarks

All trademarks are recognized, even if not explicitly identified as such. Missing designations do not mean that a product or brand is not a registered trademark.

SMA Solar Technology America LLC

6020 West Oaks Blvd.

Suite 300 Rocklin, CA 95765 U.S.A.

SMA Solar Technology Canada Inc.

2425 Matheson Blvd. E

7th Floor

Mississauga, ON L4W 5K4

Canada

Status: 5/3/2018

Copyright © 2018 SMA Solar Technology America LLC. All rights reserved.

Important Safety Instructions

SAVE THESE INSTRUCTIONS

This manual contains important instructions for:

- SBS3.8-US-10 (Sunny Boy Storage 3.8-US)
- SBS5.0-US-10 (Sunny Boy Storage 5.0-US)
- SBS6.0-US-10 (Sunny Boy Storage 6.0-US)

This manual must be followed when using this product.

The product is designed and tested in accordance with international safety requirements, but as with all electrical and electronic equipment, certain precautions must be observed when installing and/or operating the product. To reduce the risk of personal injury and to ensure the safe installation and operation of the product, you must carefully read and follow all instructions, cautions and warnings in this manual.

Warnings on this Product

The following symbols are used as product markings with the following meanings.



Beware of dangerous voltage

The product operates at high voltages. All work on the product must only be performed as described in the documentation of the product.



Beware of hot surface

The product can get hot during operation. Do not touch the product during operation.



Observe the operating instructions

Read the documentation of the product before working on it. Follow all safety precautions and instructions as described in the documentation.

General Warnings

WARNING

All electrical installations must be carried out in accordance with the local electrical standards and the *National Electrical Code*® ANSI/NFPA 70 or the *Canadian Electrical Code*® CSA C22.1. This document does not replace and is not intended to replace any local, state, provincial, federal or national laws, regulations or codes applicable to the installation and use of the product, including without limitation applicable electrical safety codes. All installations must conform with the laws, regulations, codes and standards applicable in the jurisdiction of installation. SMA assumes no responsibility for the compliance or non-compliance with such laws or codes in connection with the installation of the product.

The product contains no user-serviceable parts.

Before installing or using the product, read all of the instructions, cautions, and warnings in this manual.

Before connecting the product to the electrical utility grid, contact the local utility company. This connection must be made only by qualified personnel.

Wiring of the product must be made by qualified personnel only.

Table of Contents

1	Information on this Document	7
1.1	Validity	7
1.2	Target Group	7
1.3	Content and Structure of this Document	7
1.4	Levels of warning messages	7
1.5	Symbols in the Document	8
1.6	Typographies in the document	8
1.7	Designation in the document	8
2	Safety	9
2.1	Intended Use	9
2.2	Safety Information	9
3	Product Overview	12
3.1	Product Description	12
3.2	Interfaces and Functions	14
3.3	LED Signals	17
3.4	System Structure	19
4	Operation	21
4.1	Establishing a connection to the user interface	21
4.1.1	Establishing a Direct Connection via Ethernet	21
4.1.2	Establishing a direct connection via WLAN	21
4.1.3	Establishing a Connection via Ethernet in the local network	23
4.1.4	Establishing a Connection via WLAN in the Local Network	24
4.2	Logging In and Out of the User Interface	25
4.3	Start Page Design of the User Interface	26
4.4	Displaying and Downloading the Stored Data	28
4.5	Starting the Installation Assistant	29
4.6	Secure Power Supply Operation	30
4.6.1	Activating Secure Power Supply Operation	30
4.6.2	Deactivating Secure Power Supply Operation	31
4.7	Activate WPS Function	31
4.8	Switching WLAN On and Off	32
4.9	Changing the Password	32
4.10	Changing Operating Parameters	33
4.11	Configuring the Country Data Set	34
4.12	Configuring Feed-In Management	34
4.13	Configuring the Modbus Function	35

- 4.14 Saving the Configuration in a File..... 36
- 4.15 Adopting a Configuration from a File..... 36
- 4.16 Updating the Firmware 37
- 5 Cleaning the Inverter 39**
- 6 Troubleshooting..... 40**
 - 6.1 Forgotten Password..... 40
 - 6.2 Event Messages 41
- 7 Compliance Information 82**
- 8 Contact 83**

1 Information on this Document

1.1 Validity

This document is valid for:

- SBS3.8-US-10 (Sunny Boy Storage 3.8-US)
- SBS5.0-US-10 (Sunny Boy Storage 5.0-US)
- SBS6.0-US-10 (Sunny Boy Storage 6.0-US)

1.2 Target Group

This document is intended for qualified persons and end users. Only qualified persons are allowed to perform the activities marked in this document with a warning symbol and the caption "Qualified person". Tasks that do not require any particular qualification are not marked and can also be performed by end users. Qualified persons must have the following skills:

- Knowledge of how batteries work and are operated
- Training in how to deal with the dangers and risks associated with installing, repairing and using electrical devices, batteries and installations
- Training in the installation and commissioning of electrical devices and installations
- Knowledge of all applicable laws, standards and directives
- Knowledge of and compliance with this document and all safety information
- Knowledge of and compliance with the documents of the battery manufacturer with all safety information

1.3 Content and Structure of this Document



This document describes the configuration, operation and troubleshooting of the product as well as the operation of the product user interface.

You will find the latest version of this document and further information on the product in PDF format at www.SMA-Solar.com.

Illustrations in this document are reduced to the essential information and may deviate from the real product.

1.4 Levels of warning messages



The following levels of warning messages may occur when handling the product.

 DANGER
Indicates a hazardous situation which, if not avoided, will result in death or serious injury.
 WARNING
Indicates a hazardous situation which, if not avoided, could result in death or serious injury.
 CAUTION
Indicates a hazardous situation which, if not avoided, could result in minor or moderate injury.

NOTICE

Indicates a situation which, if not avoided, can result in property damage.

1.5 Symbols in the Document

Symbol	Explanation
	Information that is important for a specific topic or goal, but is not safety-relevant
	Example
<input type="checkbox"/>	Indicates a requirement for meeting a specific goal
<input checked="" type="checkbox"/>	Desired result
x	A problem that might occur

1.6 Typographies in the document

Typography	Use	Example
bold	<ul style="list-style-type: none"> Messages Terminals Elements on a user interface Elements to be selected Elements to be entered 	<ul style="list-style-type: none"> Connect the insulated conductors to the terminals X703:1 to X703:6. Enter 10 in the field Minutes.
>	<ul style="list-style-type: none"> Connects several elements to be selected 	<ul style="list-style-type: none"> Select Settings > Date.
[Button] [Key]	<ul style="list-style-type: none"> Button or key to be selected or pressed 	<ul style="list-style-type: none"> Select [Enter].

1.7 Designation in the document

Complete designation	Designation in this document
SMA Solar Technology America LLC	SMA
SMA Solar Technology Canada Inc.	SMA
Sunny Boy Storage	Inverter, product

2 Safety

2.1 Intended Use

The Sunny Boy Storage is an AC-coupled battery inverter for parallel grid and stand-alone mode operation. The Sunny Boy Storage converts the direct current supplied by a battery into grid-compliant alternating current. The Sunny Boy Storage, together with a battery and a compatible energy meter, make up a system for increased self-consumption (Flexible Storage System) or, together with a automatic transfer switch compatible with Sunny Boy Storage, a battery-backup system (Flexible Storage System with battery-backup function).

The product is suitable for indoor and outdoor use.

The product may only be operated with one of the energy meters approved by SMA. An updated list of energy meters approved by SMA is available at www.SMA-Solar.com.

The product must only be operated in connection with an intrinsically safe lithium-ion battery approved by SMA. An updated list of batteries approved by SMA is available at www.SMA-Solar.com.

The battery must comply with UL 1973 and must be intrinsically safe.

The communication interface of the used battery must be compatible with the product. The entire battery voltage range must be completely within the permissible input voltage range of the product. The maximum permissible DC input voltage of the product must not be exceeded.

All components must remain within their permitted operating ranges and their installation requirements at all times.

The product is approved for the US and Canadian market.

Use this product only in accordance with the information provided in the enclosed documentation and with the locally applicable standards and directives. Any other application may cause personal injury or property damage.

Alterations to the product, e.g. changes or modifications, are only permitted with the express written permission of SMA. Unauthorized alterations will void guarantee and warranty claims and in most cases terminate the operating license. SMA shall not be held liable for any damage caused by such changes.

Any use of the product other than that described in the Intended Use section does not qualify as the intended use.

The enclosed documentation is an integral part of this product. Keep the documentation in a convenient place for future reference and observe all instructions contained therein.

The type label must remain permanently attached to the product.

2.2 Safety Information

This section contains safety information that must be observed at all times when working on or with the product.

To prevent personal injury and property damage and to ensure long-term operation of the product, read this section carefully and observe all safety information at all times.

⚠ DANGER**Danger to life from electric shock due to live DC cables at the battery.**

The DC cables connected to a battery may be live. Touching the DC conductors or the live components leads to lethal electric shocks.

- Do not touch non-insulated cable ends.
- Do not touch any live components.
- Have the inverter and the battery mounted, installed and commissioned only by qualified persons with the appropriate skills.
- Observe all safety information of the battery manufacturer.
- Prior to performing any work on the inverter or the battery, disconnect the inverter from all voltage sources as described in this document.
- Wait five minutes before working on the inverter.
- If an error occurs, have it rectified by qualified persons only.

⚠ WARNING**Risk of burns due to electric arcs**

Short-circuit currents in the battery can cause heat build-up and electric arcs.

- Disconnect the battery from all voltages sources prior to performing any work on the battery.
- Observe safety information of the battery manufacturer when working on the battery or inverter.

⚠ CAUTION**Risk of burns from hot surfaces**

The surface of the inverter can get very hot. Touching the surface can result in burns.

- Mount the inverter in such a way that it cannot be touched inadvertently.
- Do not touch hot surfaces.
- Wait 30 minutes for the surface to cool sufficiently.
- Observe the safety messages on the inverter.

NOTICE**Damage to the enclosure seal in subfreezing conditions**

If you open the product when temperatures are below freezing, the enclosure seals can be damaged. Moisture can penetrate the product then.

- Only open the product if the ambient temperature is not below 0°C (32°F).
- If a layer of ice has formed on the enclosure seal when temperatures are below freezing, remove it prior to opening the product (e.g. by melting the ice with warm air). Observe the applicable safety regulations.

NOTICE**Damage due to sand, dust and moisture ingress**

Sand, dust and moisture penetration can damage the product and impair its functionality.

- Only open the product if the humidity is within the thresholds and the environment is free of sand and dust.
- Do not open the product during a dust storm or precipitation.
- Close tightly all enclosure openings.
- Only use listed rain-tight or liquid-tight conduit fittings to attach the conduits to the product.

NOTICE**Damage due to cleaning agents**

The use of cleaning agents may cause damage to the product and its components.

- Clean the product and all its components only with a cloth moistened with clear water.

NOTICE**Damage to the inverter due to electrostatic discharge**

Touching electronic components can cause damage to or destroy the inverter through electrostatic discharge.

- Ground yourself before touching any component.

**Electrical installations**

All electrical installations must be carried out in accordance with the local standards and the *National Electrical Code*® ANSI/NFPA 70 or the *Canadian Electrical Code*® CSA C22.1.

- Before connecting the inverter to the utility grid, contact your local grid operator. The electrical connection of the inverter must be carried out by qualified persons only.
- Ensure that no cables used for electrical connection are damaged.

3 Product Overview

3.1 Product Description

The Sunny Boy Storage uses the connected battery for the intermediate storage of excess PV energy in the SMA Flexible Storage System. For this purpose, the Sunny Boy Storage receives the feed-in data and purchased electricity data from the energy meter. This data is used by the Sunny Boy Storage to control the charging and discharging of the battery.

The use of an automatic transfer switch is required in the battery-backup system. In the event of grid failure, the automatic transfer switch disconnects the PV system, loads and the Sunny Boy Storage from the utility grid and creates a battery-backup grid. The battery-backup grid supplies loads that should continue to be supplied with electricity in the event of grid failure. In the event of grid failure, the Sunny Boy Storage supplies the loads with energy after a short switching time. The PV system supplies additional energy that can be used to supply the loads and charge the battery.

i Secure power supply operation in Flexible Storage Systems with backup power supply not possible

If the inverter is used in a battery-backup system and connected with an automatic transfer switch, the secure power supply operation is not available.

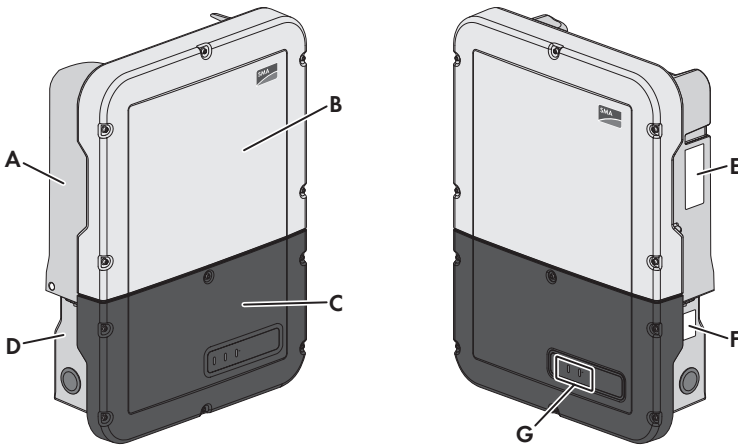









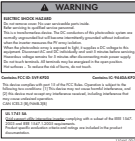

Figure 1: Design of the inverter

Position	Designation
A	Power Unit
B	Enclosure lid of the Power Unit
C	Enclosure lid for the Connection Unit
D	Connection Unit

Position	Designation
E	<p>Type label</p> <p>The type label uniquely identifies the inverter. The type label must remain permanently attached to the product. You will find the following information on the type label:</p> <ul style="list-style-type: none"> • Inverter device type (Model) • Serial number of the Power Unit (S/N) • Date of manufacture • Device-specific characteristics
F	<p>Additional type label</p> <p>The additional type label must remain permanently attached to the product. You will find the following information on the additional type label:</p> <ul style="list-style-type: none"> • Device type (Model) • Inverter serial number (S/N) • Identification key (PIC) for registration in Sunny Portal • Registration ID (RID) for registration in Sunny Portal • WLAN password (WPA2-PSK) for the direct connection to the user interface of the inverter via WLAN
G	<p>LEDs</p> <p>The LEDs indicate the operating state of the inverter.</p>

Symbols on the Product and on the Type Label

Symbol	Explanation
	<p>Inverter</p> <p>Together with the green LED, this symbol indicates the operating state of the inverter.</p>
	<p>Observe the documentation</p> <p>Together with the red LED, this symbol indicates an error.</p>
	<p>Data transmission</p> <p>Together with the blue LED, this symbol indicates the status of the network connection.</p>
	<p>Equipment Grounding Terminal</p> <p>This symbol indicates the position for the connection of an equipment grounding conductor.</p>
	<p>Risk of burns due to hot surfaces</p> <p>The product can get hot during operation. Avoid contact during operation. Prior to performing any work on the product, allow the product to cool down sufficiently.</p>

Symbol	Explanation
	<p>Danger to life due to electric shock</p> <p>The product operates at high voltages. Prior to performing any work on the product, disconnect the product from voltage sources. All work on the product must be carried out by qualified persons only.</p>
	<p>Observe the documentation</p> <p>Observe all documentation supplied with the product.</p>
	<p>Warning label with compliance information</p>
	<p>The product is has no galvanic isolation.</p>
	<p>UL 1741 und CSA C22.2 No. 107.1 are the standards applied by Underwriters Laboratories to the product to certify that it meets the requirements of the <i>National Electrical Code</i>[®], the <i>Canadian Electrical Code</i>[®] and IEEE 1547.</p>

3.2 Interfaces and Functions

The inverter is equipped with the following interfaces and functions:

User interface for monitoring and configuration

The product is equipped as standard with an integrated webserver, which provides a user interface for configuring and monitoring the product. The product user interface can be called up via the web browser if there is an existing connection to an end device (e.g. computer, tablet PC or smartphone).

SMA Speedwire

The product is equipped with SMA Speedwire as standard. SMA Speedwire is a type of communication based on the Ethernet standard. SMA Speedwire is designed for a data transfer rate of 100 Mbps and enables optimum communication between Speedwire devices within systems.

Class 1 wiring methods are to be used for field wiring connection to the terminals of the communication interface.

SMA Webconnect

The inverter is equipped with a Webconnect function as standard. The Webconnect function enables direct data transmission between the inverters of a small-scale plant and the Internet portals Sunny Portal and Sunny Places without any additional communication device and for a maximum of 1 inverters per visualized system. If there is an existing WLAN or Ethernet connection, you can directly access your visualized system via the web browser on your end device.

WLAN

The product is equipped with a WLAN interface as standard. The inverter is delivered with the WLAN interface activated as standard. If you do not want to use WLAN, you can deactivate the WLAN interface.

In addition, the product has a WPS function. The WPS function is for automatically connecting the product to a network (e.g. via router) and establish a direct connection between the product and an end device.

Modbus

The product is equipped with two Modbus interfaces.

One interface can be controlled via Ethernet and the other interface via RS485. The Modbus interface via Ethernet is designed for industrial use – via SCADA systems, for example – and deactivated as standard. The Modbus interface via Ethernet must be configured via the user interface of the inverter (if necessary). The Modbus interface via RS485 is used for data exchanges with an energy meter. The Modbus interface via RS485 must be configured via the user interface of the inverter and set on the energy meter accordingly.

The Modbus interface via Ethernet has the following tasks:

- Remote query of measured values
- Remote setting of operating parameters
- Setpoint specifications for system control
- Controlling the battery

Grid Management Services

The inverter is a grid support multi-mode inverter.

The inverter was tested in accordance with the UL 1741 SA (2016-09-07) to be compliant with the source requirements documents of the states available at the time. For connecting the inverter to the utility grid, no additional grid monitoring equipment is necessary. A description of the tested functions and instructions on the activation and setting of functions can be found in the technical information "Grid Support Utility Interactive Inverters" at www.SMA-Solar.com.

Secure power supply operation

In case of a grid failure, the secure power supply operation supplies the loads with energy from the battery. You can connect a standard outlet and a standard switch to the inverter. You can connect a load with a maximum of 16 A and 120 V to the outlet. The load is supplied with energy from the battery during grid failure. The switch is used to activate and deactivate secure power supply operation.

The secure power supply operation is not automatically activated in the event of a grid failure, neither is it automatically deactivated once the utility grid is available again. If the utility grid fails, the load supply must be activated manually by activating the switch. The inverter automatically regulates the energy supply of the outlet after activating the switch. When the utility grid is available again and the load can be supplied by this again, the secure power supply operation must be deactivated manually by switching the switch off.

During active secure power supply operation, the inverter is disconnected from the electricity and does not therefore feed into the utility grid. During secure power supply operation, the load can only be supplied with energy as long as there is stored energy available in the battery. If there is insufficient energy available from the battery, the secure power supply operation remains active, even if the utility grid is available again. Switching over to supplying the load from the utility grid does not take place automatically. Once the battery is sufficiently charged again and the load can be supplied, the secure power supply operation must be restarted.

i Secure power supply operation in Flexible Storage Systems with backup power supply not possible

If the inverter is used in a battery-backup system and connected with an automatic transfer switch, the secure power supply operation is not available.

i Do not connect any loads that require a stable energy supply

The secure power supply operation and the battery-backup operation may not be used for loads that require a stable energy supply. The energy that is available during the secure power supply operation or battery-backup operation depends on the battery capacity available and the state of charge of the battery (SOC).

- Do not connect loads if they are dependent on a stable energy supply for reliable operation.

Battery-backup function

The inverter is equipped with a battery-backup function. The battery-backup function is deactivated by default and must be activated via the user interface. The battery-backup function can only be activated if the inverter is operated in a battery-backup system with an automatic transfer switch. The battery-backup function ensures that the inverter forms a battery-backup grid that uses energy from the battery and the PV system to supply the household grid in the event of a utility grid failure. When the battery-backup operation is activated, the automatic transfer switch disconnects the PV system and the household grid from the utility grid in the event of a grid failure, and connects these to the battery-backup grid. After a short switch-over time, the battery-backup grid and loads connected can be supplied by the battery and supplemented with energy from the PV system. The loading of the battery is ensured by the existing PV system. As soon as the utility grid is available again, the battery-backup operation is deactivated automatically and the loads are supplied with energy from the utility grid. If the automatic battery-backup operation is not set, the battery-backup operation must be manually activated in the event of a grid failure, and must also be deactivated again once the utility grid is available.

An updated list of automatic transfer switches approved by SMA is available at www.SMA-Solar.com.

i Secure power supply operation in Flexible Storage Systems with backup power supply not possible

If the inverter is used in a battery-backup system and connected with an automatic transfer switch, the secure power supply operation is not available.

i Do not connect any loads that require a stable energy supply

The secure power supply operation and the battery-backup operation may not be used for loads that require a stable energy supply. The energy that is available during the secure power supply operation or battery-backup operation depends on the battery capacity available and the state of charge of the battery (SOC).

- Do not connect loads if they are dependent on a stable energy supply for reliable operation.

Black start function

The inverter has a black start function and an auxiliary battery that provides energy for the black start. In battery-backup systems, you have the possibility to install a standard switch for black starting the inverter and battery. The black-start switch is used to start the battery-backup operation manually in the event of grid failure if the battery and inverter are in sleep mode and, therefore, are unable to provide energy. When the black-start switch is switched on manually, the energy from the auxiliary battery is made available in order to automatically switch the battery and therefore also the inverter from sleep mode to operation in order that the inverter can make energy available from the battery. You can stop the battery-backup operation by switching it off manually.

SMA Smart Connected

SMA Smart Connected is the free monitoring of the inverter via the SMA Sunny Portal. Thanks to SMA Smart Connected, the PV system operator and qualified person will be informed automatically and proactively about inverter events that occur.

SMA Smart Connected is activated during registration in Sunny Portal. In order to use SMA Smart Connected, it is necessary that the inverter is permanently connected to Sunny Portal and the data of the PV system operator and qualified person is stored in Sunny Portal and up-to-date.

3.3 LED Signals

LED signal	Explanation
The green LED is flashing (two seconds on and two seconds off)	Waiting for feed-in conditions The conditions for feed-in operation are not yet met. As soon as the conditions are met, the inverter will start feed-in operation.
The green LED is flashing (1.5 s on and 0.5 s off)	Secure power supply operation or battery-backup function The secure power supply operation or battery-backup function is activated and the inverter supplies the loads with energy from the battery.

LED signal	Explanation
The green LED flashes quickly	Update of central processing unit The central processing unit of the inverter is being updated.
The green LED is glowing	Parallel grid operation
The green LED is off	The inverter is not feeding into the utility grid.
The red LED is glowing	Event occurred If an event occurs, a distinct event message and the corresponding event number will be displayed in addition on the inverter user interface or in the communication product.
The blue LED flashes slowly for approx. one minute	Communication connection is being established The inverter is establishing a connection to a local network or is establishing a direct connection to an end device via Ethernet (e.g. computer, tablet PC or smartphone).
The blue LED flashes quickly for approx. two minutes.	WPS active The WPS function is active.
The blue LED is glowing	Communication active There is an active connection with a local network or there is a direct connection with an end device via Ethernet (e.g. computer, tablet PC or smartphone).

3.4 System Structure

Flexible Storage System

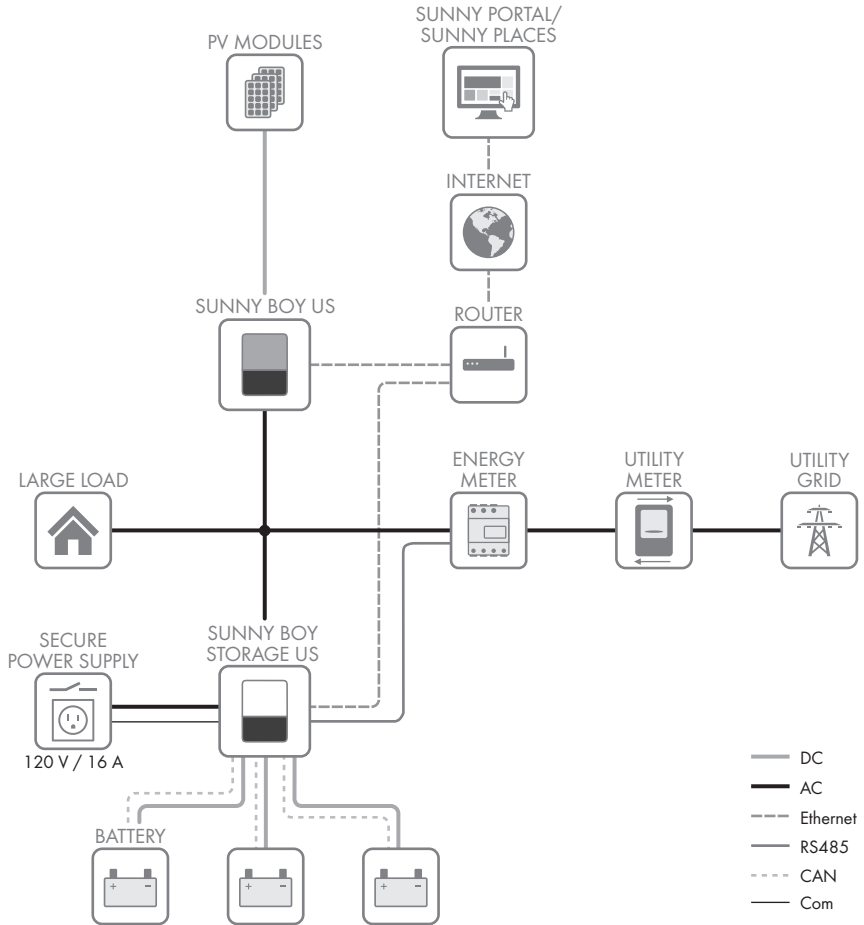

Figure 2: System design of a flexible storage system with switch and outlet for secure power supply operation (example)

SMA Flexible Storage System with Battery-Backup Function

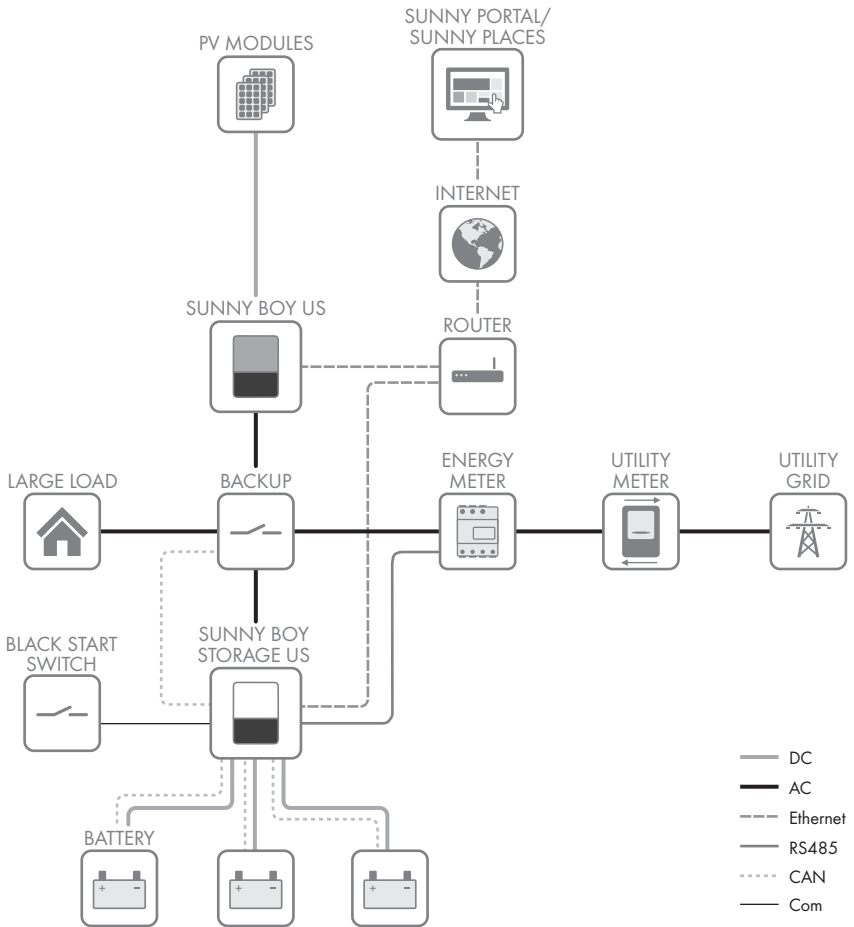

Figure 3: System design of a flexible storage system with battery-backup function (example)

4 Operation

4.1 Establishing a connection to the user interface

4.1.1 Establishing a Direct Connection via Ethernet

Requirements:

- The product must be commissioned.
- An end device (e.g. computer) with an Ethernet interface must be available.
- The product must be connected directly to the end device.
- The respective latest version of one of the following web browsers must be installed: Chrome, Edge, Firefox, Internet Explorer or Safari.
- The SMA Grid Guard code of the Installer must be available for the changing of grid-relevant settings after completion of the first ten feed-in hours or installation assistant (see "Application for SMA Grid Guard Code" at www.SMA-Solar.com). A charge is levied for this code.

i IP address of the inverter

- Standard inverter IP address for direct connection via Ethernet: 169.254.12.3

Procedure:

1. Open the web browser of your device, enter the IP address **169.254.12.3** in the address line and press the enter key.
 2. **i Web browser signals a security vulnerability**
 After the IP address has been confirmed by pressing the enter key, a message might appear indicating that the connection to the user interface of the inverter is not secure. SMA guarantees that calling up the user interface is secure.
 - Continue loading the user interface.
- The login page of the user interface opens.

4.1.2 Establishing a direct connection via WLAN

Requirements:

- The product must be commissioned.
- An end device (e.g. computer, tablet PC or smartphone) must be available.
- The respective latest version of one of the following web browsers must be installed: Chrome, Edge, Firefox, Internet Explorer or Safari.
- JavaScript must be enabled in the web browser of the end device.
- The SMA Grid Guard code of the Installer must be available for the changing of grid-relevant settings after completion of the first ten feed-in hours or installation assistant (see "Application for SMA Grid Guard Code" at www.SMA-Solar.com). A charge is levied for this code.

i Inverter SSID and IP address and necessary passwords

- Inverter SSID in WLAN: SMA[serial number] (e.g. SMA0123456789)
- Standard WLAN password (usable until completion of the configuration by means of the installation assistant or prior to the end of the first ten feed-in hours): SMA12345
- Device-specific WLAN password (usable for initial configuration to completion of the first ten feed-in hours): see WPA2-PSK on the type label of the inverter or on the back of the manual included in the delivery
- Standard IP inverter address for a direct connection via WLAN outside of a local network: 192.168.12.3

i Importing and exporting files with end devices having an iOS operating system is not possible.

For technical reasons, importing and exporting files (e.g. importing an inverter configuration, saving the current inverter configuration or exporting events) is not possible with mobile end devices having an iOS operating system.

- Use an end device that does not have an iOS operating system for importing and exporting files.

The procedure can be different depending on the end devices. If the procedure described does not apply to your end device, establish the direct connection via WLAN as described in the manual of your end device.

Procedure:

1. If your end device has a WPS function:
 - Activate the WPS function on the inverter. To do this, tap twice on the enclosure lid of the Connection Unit.
 - The blue LED flashes quickly for approx. two minutes. The WPS function is active during this time.
 - Activate the WPS on your end device.
 - The connection with your end device will be established automatically. It can take up to 20 seconds for this connection to be established.
2. If your end device has not a WPS function:
 - Search for WLAN networks with your end device.
 - Select the SSID of the inverter **SMA[serial number]** in the list with the found WLAN networks.
 - Enter the inverter WLAN password. Within the first ten feed-in hours and prior to completing the configuration by means of the installation assistant, you must use the standard WLAN password **SMA12345**. After the first ten feed-in hours or after completing the configuration by means of the installation assistant, you must use the device-specific WLAN password (WPA2-PSK) of the inverter. You find the WLAN password (WPA2-PSK) on the type label.
3. Enter the IP address **192.168.12.3** or, if your device supports mDNS services, **SMA[serial number].local** or **https://SMA[serial number]** in the address bar of the web browser and press the enter key.

4. **i** Web browser signals a security vulnerability

After the IP address has been confirmed by pressing the enter key, a message might appear indicating that the connection to the user interface of the inverter is not secure. SMA guarantees that calling up the user interface is secure.

- Continue loading the user interface.

The login page of the user interface opens.

4.1.3 Establishing a Connection via Ethernet in the local network

i New IP address for connecting with a local network

If the product is connected to a local network (e.g. via a router), the product will receive a new IP address. Depending on the type of configuration, the new IP address will be assigned automatically by the DHCP server (router) or manually by you. Upon completion of the configuration, the product can only be reached via the following access addresses:

- Generally applicable access address: IP address manually assigned or assigned by the DHCP server (router) (identification via network scanner software or network configuration of the router).
- Access address for Apple and Linux systems: SMA[serial number].local (e.g. SMA0123456789.local)
- Access address for Windows and Android systems: https://SMA[serial number] (e.g. https://SMA0123456789)

Requirements:

- The product must be connected to the local network via a network cable (e.g. via a router).
- The product must be integrated into the local network. Tip: There are various methods of integrating the product into the local network with the aid of the installation assistant.
- An end device (e.g. computer, tablet PC or smartphone) must be available.
- The end device must be in the same local network as the product.
- The respective latest version of one of the following web browsers must be installed: Chrome, Edge, Firefox, Internet Explorer or Safari.
- The SMA Grid Guard code of the Installer must be available for the changing of grid-relevant settings after completion of the first ten feed-in hours or installation assistant (see "Application for SMA Grid Guard Code" at www.SMA-Solar.com). A charge is levied for this code.

Procedure:

1. Open the web browser of your end device, enter the IP address of the inverter in the address line of the web browser and press the enter key.

2. **i** Web browser signals a security vulnerability

After the IP address has been confirmed by pressing the enter key, a message might appear indicating that the connection to the user interface of the inverter is not secure. SMA guarantees that calling up the user interface is secure.

- Continue loading the user interface.

The login page of the user interface opens.

4.1.4 Establishing a Connection via WLAN in the Local Network

i New IP address for connecting with a local network

If the product is connected to a local network (e.g. via a router), the product will receive a new IP address. Depending on the type of configuration, the new IP address will be assigned automatically by the DHCP server (router) or manually by you. Upon completion of the configuration, the product can only be reached via the following access addresses:

- Generally applicable access address: IP address manually assigned or assigned by the DHCP server (router) (identification via network scanner software or network configuration of the router).
- Access address for Apple and Linux systems: SMA[serial number].local (e.g. SMA0123456789.local)
- Access address for Windows and Android systems: https://SMA[serial number] (e.g. https://SMA0123456789)

Requirements:

- The product must be commissioned.
- The product must be integrated into the local network. Tip: There are various methods of integrating the product into the local network with the aid of the installation assistant.
- The end device must be in the same local network as the product.
- An end device (e.g. computer, tablet PC or smartphone) must be available.
- JavaScript must be enabled in the web browser of the end device.
- The respective latest version of one of the following web browsers must be installed: Chrome, Edge, Firefox, Internet Explorer or Safari.
- The SMA Grid Guard code of the Installer must be available for the changing of grid-relevant settings after completion of the first ten feed-in hours or installation assistant (see "Application for SMA Grid Guard Code" at www.SMA-Solar.com). A charge is levied for this code.

i Importing and exporting files with end devices having an iOS operating system is not possible.

For technical reasons, importing and exporting files (e.g. importing an inverter configuration, saving the current inverter configuration or exporting events) is not possible with mobile end devices having an iOS operating system.

- Use an end device that does not have an iOS operating system for importing and exporting files.

Procedure:

1. Enter the IP address of the inverter in the address bar of the web browser.
 2.  **Web browser signals a security vulnerability**
After the IP address has been confirmed by pressing the enter key, a message might appear indicating that the connection to the user interface of the inverter is not secure. SMA guarantees that calling up the user interface is secure.
 - Continue loading the user interface.
- The login page of the user interface opens.

4.2 Logging In and Out of the User Interface

After a connection to the user interface of the inverter has been established, the login page opens. Log onto the user interface as described below.

Log in as Installer or User for the First Time

Procedure:

1. In the drop-down list **Language**, select the desired language.
 2. In the **User group** drop-down list, select the entry **Installer** or **User**.
 3. In the **New password** field, enter a new password for the selected user group.
 4. In the **Repeat password** field, enter the new password again.
 5. Select **Login**.
- The **Configuring the Inverter** page opens.

Log in as the User or Installer

1. In the drop-down list **Language**, select the desired language.
 2. In the **User group** drop-down list, select the entry **Installer** or **User**.
 3. Enter the password in the field **Password**.
 4. Select **Login**.
- The start page of the user interface opens.

Log Out as the User or Installer

1. On the right-hand side of the menu bar, select the menu **User Settings**.
 2. In the subsequent context menu, select [**Logout**].
- The login page of the user interface opens. The logout was successful.

4.3 Start Page Design of the User Interface

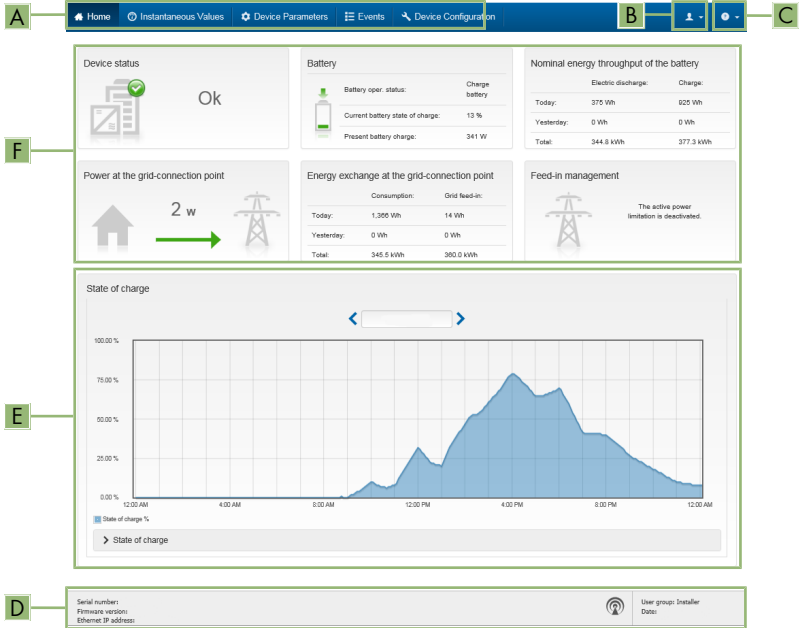

Figure 4: Start page design of the user interface (example)

Position	Designation	Description
A	Menu	<p>Provides the following functions:</p> <ul style="list-style-type: none"> • Home Opens the user interface homepage • Instantaneous values Current measured values of the inverter • Device Parameters The various operating parameters of the inverter can be viewed and configured here depending on the user group. • Events All events that have occurred in the selected time period are displayed here. The event types are Information, Warning and Error. Currently existing events of the types Error and Warning will be additionally displayed in the Device status viewlet. However, only the higher-priority event is displayed. If, for example, there is a Warning and an Error present at the same time, only the Error will be displayed. • Device configuration Various settings for the inverter can be made here. The selection available is dependent on which user group you are logged in as and the operating system of the device with which the user interface has been called up. • Data You will find all data that is saved in the internal memory of the inverter or on an external storage medium on this page.
B	User settings	<p>Provides the following functions, depending on the user group logged in:</p> <ul style="list-style-type: none"> • Starting the installation assistant • SMA Grid Guard login • Logout
C	Help	<p>Provides the following functions:</p> <ul style="list-style-type: none"> • Displaying information on Open Source licenses used • Link to the website of SMA

Position	Designation	Description
D	Status bar	<p>Displays the following information:</p> <ul style="list-style-type: none"> • Inverter serial number • Inverter firmware version • IP address of the inverter within the local network and/or IP address of the inverter during WLAN connection • With WLAN connection: Signal strength of WLAN connection • User group logged in • Date and device time of the inverter
E	State of charge	<p>Chronological sequence of the state of charge (SOC) of the battery This value may be different from the values that the battery provides. Only the value supplied by the inverter is used for this purpose.</p>
F	Status display	<p>The various areas display information on the current status of the system.</p> <ul style="list-style-type: none"> • Device status Displays whether the inverter and/or the battery is/are currently in a fault-free operating state or whether there is an event type Error or Warning present. • Feed-in management Displays whether the inverter is currently limiting its active power. • Nominal energy throughput of the battery Indicates how much energy has been charged to the battery and how much has been discharged from the battery. • Battery Displays the following information: <ul style="list-style-type: none"> - Operating status of battery - Current battery state of charge - Current battery charging power • Energy exchange at the grid-connection point Indicates how much energy was obtained from the utility grid to supply the household and how much the PV system fed in. • Power at the grid-connection point Indicates which power is currently fed in or obtained at the grid-connection point.

4.4 Displaying and Downloading the Stored Data

If an external storage device is plugged in, you can display and download the stored data.

Procedure:

1. Activate the user interface (see Section 4.1, page 21).

2. Log into the user interface (see Section 4.2, page 25).
3. Select the menu **Data**.
4. Select the folder **Data**.
5. To call up the data, select the respective folder and click on the required file.
6. To download the data, select the data type to be exported in the drop-down list. Then apply the time filter and select **Data export**.

4.5 Starting the Installation Assistant

QUALIFIED PERSON

The installation assistant leads you step-by-step through the steps necessary for the initial configuration of the inverter.

Layout of the installation assistant

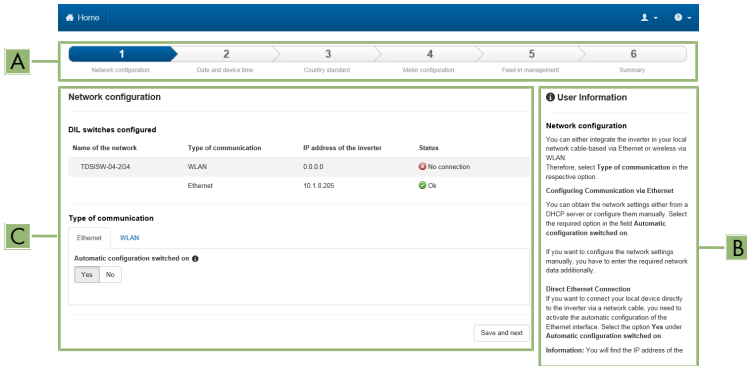

Figure 5: Layout of the installation assistant (example)

Position	Designation	Description
A	Configuration steps	Overview of the installation assistant steps. The number of steps depends on the type of device and the additionally installed modules. The current step is highlighted in blue.
B	User information	Information about the current configuration step and the setting options of the configuration step.
C	Configuration field	You can make settings in this field.

Requirement:

- When configuring after completion of the first ten feed-in hours or after exiting the installation assistant, the SMA Grid Guard code must be available in order to change the grid-relevant parameters (see "Application for SMA Grid Guard Code" at www.SMA-Solar.com). A charge is levied for this code.

Procedure:

1. Activate the user interface (see Section 4.1, page 21).
 2. Log in as **Installer**.
 3. Select the menu **User Settings** (see Section 4.3, page 26) on the start page of the user interface.
 4. In the context menu, select [**Start the installation assistant**].
- The installation assistant will open.

4.6 Secure Power Supply Operation

If an outlet and a switch for secure power supply operation are connected to the inverter, you can supply a load with energy from the battery in case of a grid failure. If you activate the secure power supply operation, the inverter supplies the loads that are connected to the outlet for secure power supply operation until the battery's state of charge (SOC) has reached the lower limit. In case the battery's state of charge (SOC) is too low, the energy supply of the outlet is permanently interrupted. The secure power supply operation is only possible again when the battery can be recharged after connecting to the utility grid.

In case of overload, the energy supply of the outlet is briefly interrupted. The inverter automatically attempts to reestablish the energy supply 20 seconds after the interruption. This can lead to inadvertent starting of the load that is connected to the outlet. Ensure that the load connected to the outlet does not consume too much power. If necessary, reduce the power consumption of the load.

i Secure power supply operation in Flexible Storage Systems with backup power supply not possible

If the inverter is used in a battery-backup system and connected with an automatic transfer switch, the secure power supply operation is not available.

i Do not connect any loads that require a stable energy supply

The secure power supply operation and the battery-backup operation may not be used for loads that require a stable energy supply. The energy that is available during the secure power supply operation or battery-backup operation depends on the battery capacity available and the state of charge of the battery (SOC).

- Do not connect loads if they are dependent on a stable energy supply for reliable operation.

4.6.1 Activating Secure Power Supply Operation

1. If no load is connected to the outlet, connect a load.
2. Turn the switch of the outlet to secure power supply operation.

3. Wait one minute.
 - The inverter commences secure power supply operation. Once the inverter supplies the outlet, the green LED flashes (1.5 s on and 0.5 s off). In addition, the control light of the outlet for secure power supply operation glows.
4. If the green LED is not flashing or the control light of the outlet is off, it is likely that the battery's state of charge (SOC) is too low and the following steps must be performed:
 - Ensure that the outlet's switch is set to secure power supply operation.
 - Connect a load with lower power consumption to the outlet.
5. If no voltage can be measured at the outlet, ensure that the switch of the outlet is set to secure power supply operation, and that the switch, outlet and control light for secure power supply operation are correctly connected.

4.6.2 Deactivating Secure Power Supply Operation

1. If necessary, disconnect the load from the outlet.
2. Turn the switch of the outlet to grid operation.
 - Grid operation is activated.
3. Switch on the AC circuit breaker.
- The inverter connects to the utility grid and starts feed-in operation.

4.7 Activate WPS Function

The WPS function can be used for different purposes:

- Automatic connection to a network (e.g. via router)
- Direct connection between the product and an end device

Depending on the intended application of the WPS function, the procedure for activation will vary.

Activating WPS function for automatic connection to a network

Requirements:

- WLAN must be activated in the product.
- WPS must be activated on the router.

Procedure:

1. Activate the user interface (see Section 4.1, page 21).
2. Log in as **Installer**.
3. Start the installation assistant (see Section 4.5, page 29).
4. Select **Network configuration**.
5. Select **WPS for WLAN network** button in the **WLAN** tab.
6. Select **Activate WPS**.
7. Select **Save and next** and exit the installation assistant.
- The WPS function is activated and the automatic connection to the network can be established.

Activating the WPS function for direct connection to the end device.

- Activate the WPS function on the inverter. To do this, tap twice on the enclosure lid of the Connection Unit.
 - ☑ The blue LED flashes quickly for approx. two minutes. The WPS function is active during this time.

4.8 Switching WLAN On and Off

The inverter is equipped with an activated WLAN interface as standard. If you do not want to use WLAN, you can switch the WLAN function off and switch it on again whenever needed. In doing so, you can switch the WLAN direct connection and the WLAN connection in the local network on independently of each other.

i Switching on the WLAN function only possible via Ethernet connection

If you switch off both the WLAN function for the direct connection and for the connection in the local network, access to the inverter user interface and therefore reactivation of the WLAN interface is only possible via an Ethernet connection.

Switching WLAN Off

If you would like to switch the WLAN function off completely, you must switch off both the direct connection and the connection in the local network.

Procedure:

- To switch off the direct connection in the parameter group **PV system communication > WLAN**, select the parameter **Soft-access-point is turned on** and set this to **No**.
- To switch off the connection in the local network in the parameter group **PV system communication > WLAN**, select the parameter **WLAN is turned on** and set this to **No**.

Switching WLAN On

If you have switched the WLAN function for direct connection or for connection in the local network off, you can switch the WLAN function back on in accordance with the following procedure.

Requirement:

- ☐ If the WLAN function was previously switched off completely, the inverter must be connected to a computer or router via Ethernet.

Procedure:

- To switch on the WLAN direct connection, in the parameter group **PV system communication > WLAN**, select the parameter **Soft-access-point is turned on** and set this to **Yes**.
- To switch on the WLAN connection in the local network, in the parameter group **System communication > WLAN**, select the parameter **WLAN is turned on** and set this to **Yes**.

4.9 Changing the Password

The password for the inverter can be changed for both user groups. Furthermore, the user group **Installer** can change the password for the user group **User** as well as its own password.

Procedure:

1. Activate the user interface (see Section 4.1, page 21).
2. Log into the user interface (see Section 4.2, page 25).
3. Call up the menu **Device Parameters**.
4. Select [**Edit parameters**].
5. In the parameter group **User Rights > Access Control** change the password of the desired user group.
6. Select [**Save all**] to save the changes.

4.10 Changing Operating Parameters

The operating parameters of the inverter are set to certain values by default. You can change the operating parameters to optimize the performance of the inverter.

This section describes the basic procedure for changing operating parameters. Always change operating parameters as described in this section. Some function-sensitive parameters can only be viewed by qualified persons and can only be changed by qualified persons by entering the personal SMA Grid Guard code.

Requirements:

- The changes to the grid-relevant parameters must be approved by the grid operator.
- When changing grid-relevant parameters, the SMA Grid Guard code must be available (see "Application for SMA Grid Guard Code" at www.SMA-Solar.com). A charge is levied for this code.

Procedure:

1. Activate the user interface (see Section 4.1, page 21).
 2. Log into the user interface (see Section 4.2, page 25).
 3. Call up the menu **Device Parameters**.
 4. Select [**Edit parameters**].
 5. Log in using the SMA Grid Guard code to change those parameters designated by a lock (only for installers):
 - Select the menu **User Settings** (see Section 4.3, page 26).
 - In the subsequent context menu, select [**SMA Grid Guard login**].
 - Enter the SMA Grid Guard code and select [**Login**].
 6. Expand the parameter group that contains the parameter which is to be configured.
 7. Change the desired parameters.
 8. Select [**Save all**] to save the changes.
- The inverter parameters are set.

4.11 Configuring the Country Data Set

⚠ QUALIFIED PERSON

Procedure:

- In the parameter group **Grid monitoring > Grid monitoring** select the parameter **Set country standard** and set the required country data set.

4.12 Configuring Feed-In Management

⚠ QUALIFIED PERSON

Starting the installation assistant

1. Activate the user interface (see Section 4.1, page 21).
2. Log in as **Installer**.
3. Start the installation assistant (see Section 4.5, page 29).
4. Select [**Save and continue**] after each step up until the step **Configure grid management service**.
5. Make the settings as described in the following.

Setting the connected line conductors

- In the tab **Feed-in management**, select the line conductor to which the inverter is connected from the drop-down list **Connected line conductors**.

Making settings for systems without a higher unit

1. Set **Feed-in management at the grid-connection point** to [**On**].
2. Enter the total PV array power in the field **Nominal PV system power**.
3. In the drop-down list **Operating mode of active power limitation at the grid-connection point**, select whether active power limitation is to be performed via a fixed specification in percent or in watts.
4. In the field **Set active power limit at the grid-connection point**, enter the value to which the active power at the grid-connection point is to be limited. The value must be set to **0** for zero export.

Making settings for systems with a higher unit

- Set **Feed-in management at the grid-connection point** to [**Off**].

Activating unbalanced load limitation

Depending on the country data set, unbalanced load limitation may have already been set. In this case, check the settings.

- If there are single-phase PV inverters in the system and unbalanced load limitation is requested, set **Unbalanced load limitation** to [**On**] and enter the maximum permissible unbalanced load in the field **Maximum unbalanced load**.
- If there are three-phase PV inverters in the system, set **Unbalanced load limitation** to [**Off**].

Setting PV inverter feed-in management

1. Activate the PV inverter user interface.
2. Log in as **Installer**.
3. Start the installation assistant on the PV inverter user interface.
4. Select [**Save and continue**] after each step up until the step **Configure grid management service**.
5. Ensure that the function **System control and power limitation** is set to [**On**].
6. In the drop-down list **Operating mode active power**, select the entry **Active power limitation P via system control**.
7. In the drop-down list **Operating mode for absent system control**, select the entry **Use fallback setting**.
8. In the field **Fallback active power P**, enter the same value as the one entered for the battery inverter. Where necessary, convert this value into a percentage. This ensures that in systems with Sunny Home Manager, the correct fallback value will be adopted in the event of a communication breakdown between Sunny Home Manager and inverter.
9. In the field **Timeout**, enter the time that the PV inverter is to wait before it limits its nominal power to the set fallback value.
10. If, in the event of a 0% or 0 W specification, the PV inverter is not permitted to feed small amounts of active power into the utility grid, select the entry **Yes** in the drop-down list **Grid disconnection at zero export**. This ensures that in the event of a 0% or 0 W specification, the inverter disconnects from the utility grid and does not feed in active power.

4.13 Configuring the Modbus Function

QUALIFIED PERSON

The Modbus interface is deactivated by default and the communication ports 502 set.

In order to access SMA inverters with SMA Modbus® or SunSpec® Modbus®, the Modbus interface must be activated. After activating the interface, the communication ports of both IP protocols can be changed. For information on commissioning and configuration of the Modbus interface, see the Technical Information "SMA Modbus® Interface" or in the Technical Information "SunSpec® Modbus® Interface" at www.SMA-Solar.com.

For information on which Modbus registers are supported, see the Technical Descriptions "SMA Modbus® Interface" or "SunSpec® Modbus® Interface" at www.SMA-Solar.com.

Data security during activated Modbus interface

If you activate the Modbus interface, there is a risk that unauthorized users may access and manipulate the data or devices in your PV system.

- Take appropriate protective measures, such as:
 - Set up a firewall.
 - Close unnecessary network ports.
 - Only enable remote access via VPN tunnel.
 - Do not set up port forwarding at the communication port in use.
 - In order to deactivate the Modbus interface, reset the inverter to default settings or deactivate the activated parameter again.

Deactivate the dynamic active power limitation for the PV inverters when controlled via Modbus

If the PV inverters and the battery inverter are controlled in a PV system via Modbus, the dynamic active power limitation of the PV inverters must be deactivated.

Procedure:

- Activate the Modbus interface and adjust the communication ports if necessary (see the technical information "SMA Modbus® Interface" or "SunSpec® Modbus® Interface" at www.SMA-Solar.com).

4.14 Saving the Configuration in a File

Procedure:

1. Activate the user interface (see Section 4.1, page 21).
2. Log into the user interface (see Section 4.2, page 25).
3. Select the menu **Device Configuration**.
4. Select [**Settings**].
5. In the context menu, select [**Saving the configuration in a file**].
6. Follow the instructions in the dialog.

4.15 Adopting a Configuration from a File

QUALIFIED PERSON

Requirements:

- The SMA Grid Guard code must be available (see "Application for SMA Grid Guard Code" at www.SMA-Solar.com). A charge is levied for this code.
- Changes to grid-relevant parameters must be approved by the responsible grid operator.

Procedure:

1. Activate the user interface (see Section 4.1, page 21).
2. Log into the user interface as an **Installer**.

3. Select the menu **Device Configuration**.
4. Select [**Settings**].
5. In the context menu, select [**Adopting the configuration from a file**].
6. Follow the instructions in the dialog.

4.16 Updating the Firmware

QUALIFIED PERSON

If no automatic update is set in the communication product (e.g. Cluster Controller, Sunny Portal) or via the user interface of the inverter, you have the option of carrying out a manual firmware update. Depending on the battery used, the firmware update of the inverter also updates the battery.

There are two options to update the firmware:

- Update the firmware via the user interface of the inverter.
- Update the firmware via USB flash drive.

Updating firmware via the user interface

Requirements:

- An update file with the desired inverter firmware must be available. The update file is, for example, available for download on the product page of the inverter at www.SMA-Solar.com. To download the update file, it is necessary to enter the serial number of the inverter.

Procedure:

1. Activate the user interface (see Section 4.1, page 21).
2. Log into the user interface (see Section 4.2, page 25).
3. Select the menu **Device Configuration**.
4. In the inverter row, click on the gear icon and select **Update firmware**.
5. Select [**Browse**] and select the update file for the inverter.
6. Select **Update firmware**.
7. Follow the instructions in the dialog.

Updating the Firmware via USB Flash Drive

Requirement:

- A USB flash drive with maximum 32 GB and file system FAT32 must be available.

Procedure:

1. Create an "UPDATE" folder on the USB stick.
2. Save the update file with the desired firmware in the "UPDATE" folder on the USB flash drive. The update file is, for example, available for download on the product page of the inverter at www.SMA-Solar.com. Make sure that only the update file to which the inverter is to be updated must be saved on the USB flash drive.

3.

⚠ DANGER**Danger to life due to high voltages**

- Disconnect the inverter from any voltage sources and open the enclosure lid of the Connection Unit (see the inverter installation manual).

4. Insert the USB flash drive in the USB port on the communication assembly.

5. Commission the inverter (see inverter installation manual).

- During start-up phase of the inverter, the desired firmware is being installed.

6.

⚠ DANGER**Danger to life due to high voltages**

- Disconnect the inverter from any voltage sources and open the enclosure lid of the Connection Unit (see the inverter installation manual).

7. Pull the USB flash drive out of the USB port.

8. Commission the inverter (see inverter installation manual).

9. Call up the user interface of the inverter and check the events to see whether a firmware update has been successfully completed.

10. If the firmware update has not been successfully completed, perform the firmware update again.

5 Cleaning the Inverter

NOTICE
Damage to the type label due to the use of cleaning agents
<ul style="list-style-type: none">• If the inverter is dirty, clean the enclosure, the enclosure lid, the type label and the LEDs with a damp cloth and clear water only.

6 Troubleshooting

6.1 Forgotten Password

If you have forgotten the password for the inverter, you can unlock the inverter with a Personal Unlocking Key (PUK). For each inverter, there is one PUK for each user group (**User** and **Installer**).
Tip: With PV systems in Sunny Portal, you can also assign a new password via Sunny Portal for the user group **Installer**. The password for the user group **Installer** is the same as the system password in Sunny Portal.

Procedure:

1. Request PUK (application form available at www.SMA-Solar.com).
2. Activate the user interface (see Section 4.1, page 21).
3. Enter the PUK instead of the password into the field **Password**.
4. Select **Login**.
5. Call up the menu **Device Parameters**.
6. Select [**Edit parameters**].
7. In the parameter group **User Rights > Access Control** change the password of the desired user group.
8. Select [**Save all**] to save the changes.

PV Systems in Sunny Portal

The password for the user group **Installer** is also the system password for the PV system in Sunny Portal. Changing the password of the user group **Installer** can lead to the inverter no longer being able to be reached by Sunny Portal.

- Assign the changed password of the user group **Installer** as the new system password in Sunny Portal (see the Sunny Portal user manual at www.SMA-Solar.com).

6.2 Event Messages

Event number	Message, cause and corrective measures
101 to 105	<p data-bbox="311 236 595 268">⚠ QUALIFIED PERSON</p> <p data-bbox="288 284 392 309">Grid fault</p> <p data-bbox="288 320 983 376">The grid voltage or grid impedance at the connection point of the inverter is too high. The inverter has disconnected from the utility grid.</p> <p data-bbox="288 387 508 411">Corrective measures:</p> <ul data-bbox="311 422 990 536" style="list-style-type: none"> <li data-bbox="311 422 931 475">• Ensure that the correct country data set has been configured (see Section 4.1.1, page 34). <li data-bbox="311 483 990 536">• Check whether the grid voltage at the connection point of the inverter is permanently in the permissible range. <p data-bbox="333 547 990 660">If the grid voltage is outside the permissible range due to local grid conditions, contact the grid operator. The grid operator must agree with an adjustment of the voltage at the feed-in point or with a change of the monitored operating limits.</p> <p data-bbox="333 668 990 721">If the grid voltage is permanently within the permissible range and this message is still displayed, contact the Service (see Section 8, page 83).</p>
202 to 206	<p data-bbox="311 738 595 770">⚠ QUALIFIED PERSON</p> <p data-bbox="288 786 392 812">Grid fault</p> <p data-bbox="288 823 990 906">The utility grid has been disconnected, the AC cable is damaged or the grid voltage at the connection point of the inverter is too low. The inverter has disconnected from the utility grid.</p> <p data-bbox="288 917 508 941">Corrective measures:</p> <ul data-bbox="311 952 990 1137" style="list-style-type: none"> <li data-bbox="311 952 784 978">• Make sure that the circuit breaker is switched on. <li data-bbox="311 986 931 1038">• Ensure that the AC cable is not damaged and that it is connected correctly. <li data-bbox="311 1046 907 1072">• Ensure that the country data set has been configured correctly. <li data-bbox="311 1080 990 1137">• Check whether the grid voltage at the connection point of the inverter is permanently in the permissible range. <p data-bbox="333 1145 990 1259">If the grid voltage is outside the permissible range due to local grid conditions, contact the grid operator. The grid operator must agree with an adjustment of the voltage at the feed-in point or with a change of the monitored operating limits.</p> <p data-bbox="333 1267 990 1319">If the grid voltage is permanently within the permissible range and this message is still displayed, contact the Service (see Section 8, page 83).</p>

Event number	Message, cause and corrective measures
301	<p data-bbox="311 188 595 220">⚠ QUALIFIED PERSON</p> <p data-bbox="288 236 392 260">Grid fault</p> <p data-bbox="288 272 994 384">The ten-minute average value of the grid voltage is no longer within the permissible range. The grid voltage or grid impedance at the connection point is too high. The inverter disconnects from the utility grid to maintain power quality.</p> <p data-bbox="288 395 508 419">Corrective measures:</p> <ul data-bbox="311 432 994 667" style="list-style-type: none"> <li data-bbox="311 432 994 603">• During the feed-in operation, check whether the grid voltage at the connection point of the inverter is permanently in the permissible range. If the grid voltage is outside the permissible range due to local grid conditions, contact the grid operator. The grid operator must agree with an adjustment of the voltage at the feed-in point or with a change of the monitored operating limits. If the grid voltage is permanently within the permissible range and this message is still displayed, contact the Service (see Section 8, page 83).
302	<p data-bbox="288 683 624 707">Active power limited AC voltage</p> <p data-bbox="288 719 975 767">The inverter has reduced its power due to a too-high grid voltage to ensure grid stability.</p> <p data-bbox="288 778 508 802">Corrective measures:</p> <ul data-bbox="311 815 1005 986" style="list-style-type: none"> <li data-bbox="311 815 1005 986">• If possible, check the grid voltage and observe how often fluctuations occur. If fluctuations occur frequently and this message is displayed often, contact the grid operator and request approval to change the operating parameters of the inverter. If the grid operator gives his approval, discuss any changes to the operating parameters with Service (see Section 8, page 83).
401 to 404	<p data-bbox="311 1002 595 1034">⚠ QUALIFIED PERSON</p> <p data-bbox="288 1050 392 1074">Grid fault</p> <p data-bbox="288 1086 1005 1134">The inverter has disconnected from the utility grid. A stand-alone grid or a very large change in the power frequency was detected.</p> <p data-bbox="288 1145 508 1169">Corrective measures:</p> <ul data-bbox="311 1182 1005 1206" style="list-style-type: none"> <li data-bbox="311 1182 1005 1206">• Check the grid connection for significant short-term frequency fluctuations.

Event number	Message, cause and corrective measures
501	<p data-bbox="311 183 599 220">⚠ QUALIFIED PERSON</p> <p data-bbox="288 231 392 263">Grid fault</p> <p data-bbox="288 271 991 327">The power frequency is not within the permissible range. The inverter has disconnected from the utility grid.</p> <p data-bbox="288 335 509 359">Corrective measures:</p> <ul data-bbox="308 367 996 582" style="list-style-type: none"> <li data-bbox="308 367 996 422">• If possible, check the power frequency and observe how often fluctuations occur. If fluctuations occur frequently and this message is displayed often, contact the grid operator and request approval to change the operating parameters of the inverter. If the grid operator gives his approval, discuss any changes to the operating parameters with Service (see Section 8, page 83).
507	<p data-bbox="288 590 649 622">Active power limited AC frequency</p> <p data-bbox="288 630 985 686">The inverter has reduced its power due to a too-high power frequency to ensure grid stability.</p> <p data-bbox="288 694 509 718">Corrective measures:</p> <ul data-bbox="308 726 1002 901" style="list-style-type: none"> <li data-bbox="308 726 1002 901">• If possible, check the power frequency and observe how often fluctuations occur. If fluctuations occur frequently and this message is displayed often, contact the grid operator and request approval to change the operating parameters of the inverter. If the grid operator gives his approval, discuss any changes to the operating parameters with Service (see Section 8, page 83).
601	<p data-bbox="311 909 599 946">⚠ QUALIFIED PERSON</p> <p data-bbox="288 957 392 989">Grid fault</p> <p data-bbox="288 997 980 1053">The inverter has detected an excessively high proportion of direct current in the grid current.</p> <p data-bbox="288 1061 509 1085">Corrective measures:</p> <ul data-bbox="308 1093 968 1187" style="list-style-type: none"> <li data-bbox="308 1093 968 1125">• Check the grid connection for direct current. <li data-bbox="308 1125 968 1187">• If this message is displayed frequently, contact the grid operator and check whether the monitoring threshold on the inverter can be raised.

Event number	Message, cause and corrective measures
701	<p data-bbox="308 183 593 215">⚠ QUALIFIED PERSON</p> <p data-bbox="285 231 677 263">Freq. not permitted > Check parameter</p> <p data-bbox="285 271 991 327">The power frequency is not within the permissible range. The inverter has disconnected from the utility grid.</p> <p data-bbox="285 335 509 359">Corrective measures:</p> <ul data-bbox="308 367 996 574" style="list-style-type: none"> <li data-bbox="308 367 907 422">• If possible, check the power frequency and observe how often fluctuations occur. If fluctuations occur frequently and this message is displayed often, contact the grid operator and request approval to change the operating parameters of the inverter. <li data-bbox="308 518 940 574">• If the grid operator gives his approval, discuss any changes to the operating parameters with Service (see Section 8, page 83).
1001	<p data-bbox="308 590 593 622">⚠ QUALIFIED PERSON</p> <p data-bbox="285 638 638 670">L/N swapped > Check connection</p> <p data-bbox="285 678 649 702">The connection of L and N is swapped.</p> <p data-bbox="285 710 509 734">Corrective measures:</p> <ul data-bbox="308 742 974 774" style="list-style-type: none"> <li data-bbox="308 742 974 774">• Ensure that L and N are correctly connected (see installation manual).
1101	<p data-bbox="308 790 593 821">⚠ QUALIFIED PERSON</p> <p data-bbox="285 837 565 869">2nd phase connected to N</p> <p data-bbox="285 877 688 901">A second line conductor is connected to N.</p> <p data-bbox="285 909 509 933">Corrective measures:</p> <ul data-bbox="308 941 896 973" style="list-style-type: none"> <li data-bbox="308 941 896 973">• Connect the neutral conductor to N (see installation manual).
1302	<p data-bbox="308 989 593 1021">⚠ QUALIFIED PERSON</p> <p data-bbox="285 1037 744 1069">Phase(s) or neutral conductor not connected</p> <p data-bbox="285 1077 492 1101">L or N not connected.</p> <p data-bbox="285 1109 509 1133">Corrective measures:</p> <ul data-bbox="308 1141 1008 1260" style="list-style-type: none"> <li data-bbox="308 1141 890 1165">• Ensure that L and N are connected (see installation manual). <li data-bbox="308 1173 1008 1228">• Ensure that the AC conductors are not damaged and correctly connected (see installation manual). <li data-bbox="308 1236 784 1260">• Make sure that the circuit breaker is switched on.

Event number	Message, cause and corrective measures
1501	<p data-bbox="308 183 593 215">⚠ QUALIFIED PERSON</p> <p data-bbox="285 231 532 263">Reconnection fault grid</p> <p data-bbox="285 271 996 359">The changed country data set or the value of a parameter you have set does not correspond to the local requirements. The inverter cannot connect to the utility grid.</p> <p data-bbox="285 367 509 391">Corrective measures:</p> <ul data-bbox="308 399 1008 454" style="list-style-type: none"> • Ensure that the country data set has been configured correctly. To do this, select the parameter Set country standard and check the value.
3301 to 3303	<p data-bbox="308 470 593 502">⚠ QUALIFIED PERSON</p> <p data-bbox="285 518 492 550">Unstable operation</p> <p data-bbox="285 558 1002 614">There is not enough power at the DC input of the inverter for stable operation. The inverter cannot connect to the utility grid.</p> <p data-bbox="285 622 509 646">Corrective measures:</p> <ul data-bbox="308 654 856 678" style="list-style-type: none"> • Ensure that the correct battery type has been configured.
3401 to 3407	<p data-bbox="308 694 593 726">⚠ QUALIFIED PERSON</p> <p data-bbox="285 742 700 774">DC overvoltage > Disconnect generator</p> <p data-bbox="285 782 823 805">Overvoltage at the DC input. This can destroy the inverter.</p> <p data-bbox="285 813 509 837">Corrective measures:</p> <ul data-bbox="308 845 1008 1093" style="list-style-type: none"> • Immediately disconnect the inverter from all voltage sources. • Check whether the DC voltage is below the maximum input voltage of the inverter. If the DC voltage is below the maximum DC voltage of the inverter, reconnect the DC connectors to the inverter. • If the DC voltage is above the maximum DC voltage of the inverter, ensure that the correct battery has been selected. • If this message is repeated frequently, contact the Service (see Section 8, page 83).
3501	<p data-bbox="308 1109 593 1141">⚠ QUALIFIED PERSON</p> <p data-bbox="285 1157 660 1189">Insulation failure > Check generator</p> <p data-bbox="285 1197 800 1220">The inverter has detected a ground fault on the DC side.</p> <p data-bbox="285 1228 509 1252">Corrective measures:</p> <ul data-bbox="308 1260 812 1292" style="list-style-type: none"> • Check the battery and DC cabling for ground faults.

Event number	Message, cause and corrective measures
3601	<p data-bbox="311 183 595 220">⚠ QUALIFIED PERSON</p> <p data-bbox="288 231 696 263">High discharge curr. > Check generator</p> <p data-bbox="288 271 949 327">The leakage current of the inverter and the battery is too high. There is a ground fault, a residual current or a malfunction.</p> <p data-bbox="288 335 987 422">The inverter interrupts parallel grid operation immediately after exceeding a threshold. When the fault is eliminated, the inverter automatically reconnects to the utility grid.</p> <p data-bbox="288 430 509 454">Corrective measures:</p> <ul data-bbox="311 462 812 486" style="list-style-type: none"> • Check the battery and DC cabling for ground faults.
3701	<p data-bbox="311 502 595 539">⚠ QUALIFIED PERSON</p> <p data-bbox="288 550 680 582">Resid.curr.too.high > Check generator</p> <p data-bbox="288 590 987 646">The inverter detected a residual current due to brief grounding of the battery or the DC cabling.</p> <p data-bbox="288 654 509 678">Corrective measures:</p> <ul data-bbox="311 686 812 710" style="list-style-type: none"> • Check the battery and DC cabling for ground faults.
3801 to 3805	<p data-bbox="311 726 595 762">⚠ QUALIFIED PERSON</p> <p data-bbox="288 774 644 805">DC overcurrent > Check generator</p> <p data-bbox="288 813 980 837">Overcurrent at the DC input. The inverter briefly interrupts feed-in operation.</p> <p data-bbox="288 845 509 869">Corrective measures:</p> <ul data-bbox="311 877 987 933" style="list-style-type: none"> • If this message is displayed frequently, ensure that the battery has been correctly connected and that the correct battery has been selected.
3901	<p data-bbox="311 949 595 986">⚠ QUALIFIED PERSON</p> <p data-bbox="288 997 481 1029">DC power too low</p> <p data-bbox="288 1037 509 1061">Corrective measures:</p> <ul data-bbox="311 1069 999 1189" style="list-style-type: none"> • Check whether a new firmware version is available for the inverter and the battery. If a newer version is available, perform the firmware update. • If no new firmware version is available, check for other events. If there are other events, carry out the corrective measures for the other events.

Event number	Message, cause and corrective measures
3902	<p data-bbox="311 183 593 215">⚠ QUALIFIED PERSON</p> <p data-bbox="288 231 565 263">Generator voltage too low</p> <p data-bbox="288 271 509 295">Corrective measures:</p> <ul data-bbox="311 303 1002 454" style="list-style-type: none"> <li data-bbox="311 303 1002 359">• Check whether a new firmware version is available for the inverter and the battery. If a newer version is available, perform the firmware update. <li data-bbox="311 367 1002 454">• If a new firmware version is not available, check whether there are other event messages. If there are further event messages, perform the corrective measures of the further messages.
6001	<p data-bbox="311 470 593 502">⚠ QUALIFIED PERSON</p> <p data-bbox="288 518 509 550">System data restored</p> <p data-bbox="288 558 509 582">Corrective measures:</p> <ul data-bbox="311 590 968 646" style="list-style-type: none"> <li data-bbox="311 590 968 646">• If this message is displayed again, contact the Service (see Section 8, page 83).
6002	<p data-bbox="311 662 593 694">⚠ QUALIFIED PERSON</p> <p data-bbox="288 710 520 742">System data defective</p> <p data-bbox="288 750 509 774">Corrective measures:</p> <ul data-bbox="311 782 968 837" style="list-style-type: none"> <li data-bbox="311 782 968 837">• If this message is displayed again, contact the Service (see Section 8, page 83).
6003	<p data-bbox="311 853 593 885">⚠ QUALIFIED PERSON</p> <p data-bbox="288 901 621 933">System data access not possible</p> <p data-bbox="288 941 509 965">Corrective measures:</p> <ul data-bbox="311 973 968 1029" style="list-style-type: none"> <li data-bbox="311 973 968 1029">• If this message is displayed again, contact the Service (see Section 8, page 83).
6004	<p data-bbox="311 1045 593 1077">⚠ QUALIFIED PERSON</p> <p data-bbox="288 1093 532 1125">Main memory defective</p> <p data-bbox="288 1133 509 1157">Corrective measures:</p> <ul data-bbox="311 1165 968 1220" style="list-style-type: none"> <li data-bbox="311 1165 968 1220">• If this message is displayed again, contact the Service (see Section 8, page 83).
6005	<p data-bbox="311 1236 593 1268">⚠ QUALIFIED PERSON</p> <p data-bbox="288 1284 532 1316">Code memory defective</p> <p data-bbox="288 1324 509 1348">Corrective measures:</p> <ul data-bbox="311 1356 968 1410" style="list-style-type: none"> <li data-bbox="311 1356 968 1410">• If this message is displayed again, contact the Service (see Section 8, page 83).

Event number	Message, cause and corrective measures
6006	<p data-bbox="311 183 596 220">⚠ QUALIFIED PERSON</p> <p data-bbox="288 231 453 263">CPU self-test HP</p> <p data-bbox="288 271 509 295">Corrective measures:</p> <ul data-bbox="311 303 968 359" style="list-style-type: none"> <li data-bbox="311 303 968 359">• If this message is displayed again, contact the Service (see Section 8, page 83).
6009	<p data-bbox="288 375 487 406">Data inconsistency</p> <p data-bbox="288 414 509 438">Corrective measures:</p> <ul data-bbox="311 446 968 502" style="list-style-type: none"> <li data-bbox="311 446 968 502">• If this message is displayed again, contact the Service (see Section 8, page 83).
6101	<p data-bbox="311 510 596 547">⚠ QUALIFIED PERSON</p> <p data-bbox="288 558 487 590">24 h watchdog test</p> <p data-bbox="288 598 509 622">Corrective measures:</p> <ul data-bbox="311 630 968 686" style="list-style-type: none"> <li data-bbox="311 630 968 686">• If this message is displayed again, contact the Service (see Section 8, page 83).
6105	<p data-bbox="311 702 596 738">⚠ QUALIFIED PERSON</p> <p data-bbox="288 750 520 782">Execution (Operation)</p> <p data-bbox="288 790 476 813">Processor defective.</p> <p data-bbox="288 821 509 845">Corrective measures:</p> <ul data-bbox="311 853 756 893" style="list-style-type: none"> <li data-bbox="311 853 756 893">• Contact the Service (see Section 8, page 83).
6107	<p data-bbox="311 901 596 938">⚠ QUALIFIED PERSON</p> <p data-bbox="288 949 554 981">Execution (State machine)</p> <p data-bbox="288 989 476 1013">Processor defective.</p> <p data-bbox="288 1021 509 1045">Corrective measures:</p> <ul data-bbox="311 1053 756 1093" style="list-style-type: none"> <li data-bbox="311 1053 756 1093">• Contact the Service (see Section 8, page 83).
6109	<p data-bbox="311 1101 596 1137">⚠ QUALIFIED PERSON</p> <p data-bbox="288 1149 476 1181">General BSP fault</p> <p data-bbox="288 1189 476 1212">Processor defective.</p> <p data-bbox="288 1220 509 1244">Corrective measures:</p> <ul data-bbox="311 1252 756 1283" style="list-style-type: none"> <li data-bbox="311 1252 756 1283">• Contact the Service (see Section 8, page 83).

Event number	Message, cause and corrective measures
6111	<p data-bbox="311 188 595 220">⚠ QUALIFIED PERSON</p> <p data-bbox="288 236 573 268">Execution (SharedMemory)</p> <p data-bbox="288 274 472 300">Processor defective.</p> <p data-bbox="288 306 506 331">Corrective measures:</p> <ul data-bbox="311 338 752 370" style="list-style-type: none"> <li data-bbox="311 338 752 370">• Contact the Service (see Section 8, page 83).
6112	<p data-bbox="311 387 595 419">⚠ QUALIFIED PERSON</p> <p data-bbox="288 435 517 467">Execution (Watchdog)</p> <p data-bbox="288 474 472 499">Processor defective.</p> <p data-bbox="288 505 506 531">Corrective measures:</p> <ul data-bbox="311 537 752 569" style="list-style-type: none"> <li data-bbox="311 537 752 569">• Contact the Service (see Section 8, page 83).
6121	<p data-bbox="311 579 595 611">⚠ QUALIFIED PERSON</p> <p data-bbox="288 627 450 659">Watchdog DSP</p> <p data-bbox="288 665 472 691">Processor defective.</p> <p data-bbox="288 697 506 722">Corrective measures:</p> <ul data-bbox="311 729 752 761" style="list-style-type: none"> <li data-bbox="311 729 752 761">• Contact the Service (see Section 8, page 83).
6155	<p data-bbox="311 770 595 802">⚠ QUALIFIED PERSON</p> <p data-bbox="288 818 472 850">Version test failed</p> <p data-bbox="288 857 472 882">Processor defective.</p> <p data-bbox="288 888 506 914">Corrective measures:</p> <ul data-bbox="311 920 752 952" style="list-style-type: none"> <li data-bbox="311 920 752 952">• Contact the Service (see Section 8, page 83).
6202	<p data-bbox="311 962 595 994">⚠ QUALIFIED PERSON</p> <p data-bbox="288 1010 472 1042">DI converter fault</p> <p data-bbox="288 1048 472 1074">Measurement error.</p> <p data-bbox="288 1080 506 1106">Corrective measures:</p> <ul data-bbox="311 1112 752 1144" style="list-style-type: none"> <li data-bbox="311 1112 752 1144">• Contact the Service (see Section 8, page 83).
6301	<p data-bbox="311 1153 595 1185">⚠ QUALIFIED PERSON</p> <p data-bbox="288 1201 551 1233">Offset grid current sensor</p> <p data-bbox="288 1240 472 1265">Measurement error.</p> <p data-bbox="288 1272 506 1297">Corrective measures:</p> <ul data-bbox="311 1303 752 1335" style="list-style-type: none"> <li data-bbox="311 1303 752 1335">• Contact the Service (see Section 8, page 83).

Event number	Message, cause and corrective measures
6304	<p data-bbox="311 183 593 215">⚠ QUALIFIED PERSON</p> <p data-bbox="288 231 632 263">Grid voltage measurement offset</p> <p data-bbox="288 271 476 295">Measurement error.</p> <p data-bbox="288 303 509 327">Corrective measures:</p> <ul data-bbox="311 335 756 367" style="list-style-type: none"> • Contact the Service (see Section 8, page 83).
6305	<p data-bbox="311 383 593 414">⚠ QUALIFIED PERSON</p> <p data-bbox="288 430 666 462">Deviation grid voltage measurement</p> <p data-bbox="288 470 476 494">Measurement error.</p> <p data-bbox="288 502 509 526">Corrective measures:</p> <ul data-bbox="311 534 756 566" style="list-style-type: none"> • Contact the Service (see Section 8, page 83).
6306	<p data-bbox="311 574 593 606">⚠ QUALIFIED PERSON</p> <p data-bbox="288 622 655 654">DC voltage measurement deviation</p> <p data-bbox="288 662 476 686">Measurement error.</p> <p data-bbox="288 694 509 718">Corrective measures:</p> <ul data-bbox="311 726 756 758" style="list-style-type: none"> • Contact the Service (see Section 8, page 83).
6401	<p data-bbox="311 766 593 798">⚠ QUALIFIED PERSON</p> <p data-bbox="288 813 655 845">Sensor system insulation resistance</p> <p data-bbox="288 853 476 877">Measurement error.</p> <p data-bbox="288 885 509 909">Corrective measures:</p> <ul data-bbox="311 917 756 949" style="list-style-type: none"> • Contact the Service (see Section 8, page 83).
6403	<p data-bbox="311 957 593 989">⚠ QUALIFIED PERSON</p> <p data-bbox="288 1005 532 1037">Overvoltage grid (HW)</p> <p data-bbox="288 1045 509 1069">Corrective measures:</p> <ul data-bbox="311 1077 991 1268" style="list-style-type: none"> • If there are several inverters in the system, check whether they also display this event message. If all inverters display this event message, a grid error is present. • If there is only one inverter, check for a grid error. • If there is no grid error and this message is displayed again, contact the Service (see Section 8, page 83).

Event number	Message, cause and corrective measures
6404	<p data-bbox="308 183 593 215">⚠ QUALIFIED PERSON</p> <p data-bbox="285 231 532 263">Overvoltage grid (HW)</p> <p data-bbox="285 271 509 295">Corrective measures:</p> <ul data-bbox="308 303 1002 422" style="list-style-type: none"> • Check whether there is a new firmware version available for the inverter. If a newer version is available, perform the firmware update. • If no new firmware version is available, please contact Service (see Section 8, page 83).
6405	<p data-bbox="308 438 593 470">⚠ QUALIFIED PERSON</p> <p data-bbox="285 486 688 518">Overvoltage intermediate circuit (HW)</p> <p data-bbox="285 526 509 550">Corrective measures:</p> <ul data-bbox="308 558 1002 678" style="list-style-type: none"> • Check whether there is a new firmware version available for the inverter. If a newer version is available, perform the firmware update. • If no new firmware version is available, please contact Service (see Section 8, page 83).
6406	<p data-bbox="308 694 593 726">⚠ QUALIFIED PERSON</p> <p data-bbox="285 742 560 774">Overcurrent input A (HW)</p> <p data-bbox="285 782 509 805">Corrective measures:</p> <ul data-bbox="308 813 1002 1061" style="list-style-type: none"> • Check whether a new firmware version is available for the inverter and the battery. If a newer version is available, perform the firmware update. • If no new firmware version is available, check for other events. If there are other events, carry out the corrective measures for the other events. • Check the battery for any faults. • Ensure that there is not a short circuit present at the DC connection. • If this message is displayed again, contact the Service (see Section 8, page 83).
6407	<p data-bbox="308 1077 593 1109">⚠ QUALIFIED PERSON</p> <p data-bbox="285 1125 560 1157">Overcurrent input B (HW)</p> <p data-bbox="285 1165 509 1189">Corrective measures:</p> <ul data-bbox="308 1197 1002 1444" style="list-style-type: none"> • Check whether a new firmware version is available for the inverter and the battery. If a newer version is available, perform the firmware update. • If no new firmware version is available, check for other events. If there are other events, carry out the corrective measures for the other events. • Check the battery for any faults. • Ensure that there is not a short circuit present at the DC connection. • If this message is displayed again, contact the Service (see Section 8, page 83).

Event number	Message, cause and corrective measures
6408	<p data-bbox="311 183 599 220">⚠ QUALIFIED PERSON</p> <p data-bbox="288 231 453 263">UCE monitoring</p> <p data-bbox="288 268 509 300">Corrective measures:</p> <ul data-bbox="311 303 968 359" style="list-style-type: none"> <li data-bbox="311 303 968 359">• If this message is displayed again, contact the Service (see Section 8, page 83).
6409	<p data-bbox="311 375 599 411">⚠ QUALIFIED PERSON</p> <p data-bbox="288 422 487 454">Bridge short-circuit</p> <p data-bbox="288 459 509 491">Corrective measures:</p> <ul data-bbox="311 494 968 550" style="list-style-type: none"> <li data-bbox="311 494 968 550">• If this message is displayed again, contact the Service (see Section 8, page 83).
6410	<p data-bbox="311 566 599 603">⚠ QUALIFIED PERSON</p> <p data-bbox="288 614 666 646">On-board supply system disturbance</p> <p data-bbox="288 651 509 683">Corrective measures:</p> <ul data-bbox="311 686 968 742" style="list-style-type: none"> <li data-bbox="311 686 968 742">• If this message is displayed again, contact the Service (see Section 8, page 83).
6411	<p data-bbox="311 758 599 794">⚠ QUALIFIED PERSON</p> <p data-bbox="288 805 408 837">Power unit</p> <p data-bbox="288 842 509 874">Corrective measures:</p> <ul data-bbox="311 877 968 933" style="list-style-type: none"> <li data-bbox="311 877 968 933">• If this message is displayed again, contact the Service (see Section 8, page 83).
6412	<p data-bbox="311 949 599 986">⚠ QUALIFIED PERSON</p> <p data-bbox="288 997 554 1029">Overcurrent input C (HW)</p> <p data-bbox="288 1034 509 1066">Corrective measures:</p> <ul data-bbox="311 1069 1002 1316" style="list-style-type: none"> <li data-bbox="311 1069 1002 1125">• Check whether a new firmware version is available for the inverter and the battery. If a newer version is available, perform the firmware update. <li data-bbox="311 1129 1002 1185">• If no new firmware version is available, check for other events. If there are other events, carry out the corrective measures for the other events. <li data-bbox="311 1190 632 1222">• Check the battery for any faults. <li data-bbox="311 1227 946 1259">• Ensure that there is not a short circuit present at the DC connection. <li data-bbox="311 1264 968 1319">• If this message is displayed again, contact the Service (see Section 8, page 83).

Event number	Message, cause and corrective measures
6415	<p data-bbox="311 188 595 220">⚠ QUALIFIED PERSON</p> <p data-bbox="288 236 520 263">Reference voltage test</p> <p data-bbox="288 271 509 298">Corrective measures:</p> <ul data-bbox="311 306 968 363" style="list-style-type: none"> <li data-bbox="311 306 968 363">• If this message is displayed again, contact the Service (see Section 8, page 83).
6416	<p data-bbox="311 379 595 411">⚠ QUALIFIED PERSON</p> <p data-bbox="288 427 576 454">External watchdog (enable)</p> <p data-bbox="288 462 509 489">Corrective measures:</p> <ul data-bbox="311 497 968 555" style="list-style-type: none"> <li data-bbox="311 497 968 555">• If this message is displayed again, contact the Service (see Section 8, page 83).
6462	<p data-bbox="311 571 595 603">⚠ QUALIFIED PERSON</p> <p data-bbox="288 619 554 646">Overcurrent battery (HW)</p> <p data-bbox="288 654 509 681">Corrective measures:</p> <ul data-bbox="311 689 996 810" style="list-style-type: none"> <li data-bbox="311 689 996 746">• Check whether a new firmware version is available for the inverter and the battery. If a newer version is available, perform the firmware update. <li data-bbox="311 754 996 810">• If no new firmware version is available and this message is displayed again, contact the Service (see Section 8, page 83).
6499	<p data-bbox="311 826 595 858">⚠ QUALIFIED PERSON</p> <p data-bbox="288 874 722 901">Precharging overload protection triggered</p> <p data-bbox="288 909 509 936">Corrective measures:</p> <ul data-bbox="311 944 968 1002" style="list-style-type: none"> <li data-bbox="311 944 968 1002">• If this message is displayed again, contact the Service (see Section 8, page 83).
6501	<p data-bbox="311 1018 595 1050">⚠ QUALIFIED PERSON</p> <p data-bbox="288 1066 554 1093">Overtemperature interior</p> <p data-bbox="288 1101 509 1128">Corrective measures:</p> <ul data-bbox="311 1136 963 1316" style="list-style-type: none"> <li data-bbox="311 1136 963 1163">• Check whether the airflow is free of dirt. <li data-bbox="311 1171 963 1228">• Ensure that the ambient temperature does not exceed the maximum permissible temperatures. <li data-bbox="311 1236 963 1316">• If the maximum permissible temperatures are met at all times and this message is displayed again, contact the Service (see Section 8, page 83).

Event number	Message, cause and corrective measures
6502	<p data-bbox="308 183 593 215">⚠ QUALIFIED PERSON</p> <p data-bbox="285 231 588 263">Overtemperature power unit</p> <p data-bbox="285 271 509 295">Corrective measures:</p> <ul data-bbox="308 303 963 486" style="list-style-type: none"> • Check whether the airflow is free of dirt. • Ensure that the ambient temperature does not exceed the maximum permissible temperatures. • If the maximum permissible temperatures are met at all times and this message is displayed again, contact the Service (see Section 8, page 83).
6509	<p data-bbox="308 502 593 534">⚠ QUALIFIED PERSON</p> <p data-bbox="285 550 638 582">Overtemperature boost converter</p> <p data-bbox="285 590 509 614">Corrective measures:</p> <ul data-bbox="308 622 963 805" style="list-style-type: none"> • Check whether the airflow is free of dirt. • Ensure that the ambient temperature does not exceed the maximum permissible temperatures. • If the maximum permissible temperatures are met at all times and this message is displayed again, contact the Service (see Section 8, page 83).
6512	<p data-bbox="285 813 756 845">Minimum operating temperature not reached</p> <p data-bbox="285 853 946 909">The inverter will only recommence grid feed-in once the temperature has reached at least -25°C.</p>
6603	<p data-bbox="308 925 593 957">⚠ QUALIFIED PERSON</p> <p data-bbox="285 973 520 1005">Overcurrent grid (SW)</p> <p data-bbox="285 1013 509 1037">Corrective measures:</p> <ul data-bbox="308 1045 991 1228" style="list-style-type: none"> • If there are several inverters in the system, check whether they also display this event message. If all inverters display this event message, a grid error is present. • If there is only one inverter, check for a grid error. • If there is no grid error and this message is displayed again, contact the Service (see Section 8, page 83).

Event number	Message, cause and corrective measures
6604	<p data-bbox="308 183 593 215">⚠ QUALIFIED PERSON</p> <p data-bbox="285 231 677 263">Overvoltage intermediate circuit (SW)</p> <p data-bbox="285 271 509 295">Corrective measures:</p> <ul data-bbox="308 303 1002 486" style="list-style-type: none"> • Check whether there is a new firmware version available for the inverter. If a newer version is available, perform the firmware update. • If no new firmware version is available, please contact Service (see Section 8, page 83). • Check whether there was a DC overvoltage. If DC overvoltage was present, contact the Service (see Section 8, page 83).
6607	<p data-bbox="308 502 593 534">⚠ QUALIFIED PERSON</p> <p data-bbox="285 550 655 582">Charge battery overcurr. (SW limit)</p> <p data-bbox="285 590 509 614">Corrective measures:</p> <ul data-bbox="308 622 1002 742" style="list-style-type: none"> • Check whether a new firmware version is available for the inverter and the battery. If a newer version is available, perform the firmware update. • If no new firmware version is available and this message is displayed again, contact the Service (see Section 8, page 83).
6608	<p data-bbox="308 758 593 790">⚠ QUALIFIED PERSON</p> <p data-bbox="285 805 588 837">Disch. battery overcurr. (SW)</p> <p data-bbox="285 845 509 869">Corrective measures:</p> <ul data-bbox="308 877 1002 997" style="list-style-type: none"> • Check whether a new firmware version is available for the inverter and the battery. If a newer version is available, perform the firmware update. • If no new firmware version is available and this message is displayed again, contact the Service (see Section 8, page 83).
6609	<p data-bbox="308 1013 593 1045">⚠ QUALIFIED PERSON</p> <p data-bbox="285 1061 621 1093">Battery undervoltage (SW limit)</p> <p data-bbox="285 1101 509 1125">Corrective measures:</p> <ul data-bbox="308 1133 1002 1252" style="list-style-type: none"> • Check whether a new firmware version is available for the inverter and the battery. If a newer version is available, perform the firmware update. • If no new firmware version is available and this message is displayed again, contact the Service (see Section 8, page 83).

Event number	Message, cause and corrective measures
6610	<p data-bbox="308 183 593 215">⚠ QUALIFIED PERSON</p> <p data-bbox="285 231 604 263">Battery overvoltage (SW limit)</p> <p data-bbox="285 271 504 295">Corrective measures:</p> <ul data-bbox="308 303 996 422" style="list-style-type: none"> <li data-bbox="308 303 996 359">• Check whether a new firmware version is available for the inverter and the battery. If a newer version is available, perform the firmware update. <li data-bbox="308 367 996 422">• If no new firmware version is available and this message is displayed again, contact the Service (see Section 8, page 83).
6701	<p data-bbox="308 438 593 470">⚠ QUALIFIED PERSON</p> <p data-bbox="285 486 487 518">Program Sequence</p> <p data-bbox="285 526 504 550">Corrective measures:</p> <ul data-bbox="308 558 996 678" style="list-style-type: none"> <li data-bbox="308 558 996 614">• Check whether a new firmware version is available for the inverter and the battery. If a newer version is available, perform the firmware update. <li data-bbox="308 622 996 678">• If no new firmware version is available and this message is displayed again, contact the Service (see Section 8, page 83).
6702	<p data-bbox="308 694 593 726">⚠ QUALIFIED PERSON</p> <p data-bbox="285 742 453 774">No system data</p> <p data-bbox="285 782 504 805">Corrective measures:</p> <ul data-bbox="308 813 996 933" style="list-style-type: none"> <li data-bbox="308 813 996 869">• Check whether a new firmware version is available for the inverter and the battery. If a newer version is available, perform the firmware update. <li data-bbox="308 877 996 933">• If no new firmware version is available and this message is displayed again, contact the Service (see Section 8, page 83).
6801	<p data-bbox="308 949 593 981">⚠ QUALIFIED PERSON</p> <p data-bbox="285 997 565 1029">Offset DC current sensor A</p> <p data-bbox="285 1037 504 1061">Corrective measures:</p> <ul data-bbox="308 1069 996 1125" style="list-style-type: none"> <li data-bbox="308 1069 996 1125">• If this message is displayed again, contact the Service (see Section 8, page 83).
6802	<p data-bbox="308 1141 593 1173">⚠ QUALIFIED PERSON</p> <p data-bbox="285 1189 610 1220">DC converter string A defective</p> <p data-bbox="285 1228 504 1252">Corrective measures:</p> <ul data-bbox="308 1260 996 1316" style="list-style-type: none"> <li data-bbox="308 1260 996 1316">• If this message is displayed again, contact the Service (see Section 8, page 83).

Event number	Message, cause and corrective measures
6901	<p data-bbox="314 188 583 220">⚠ QUALIFIED PERSON</p> <p data-bbox="292 236 561 260">Offset DC current sensor B</p> <p data-bbox="292 272 507 296">Corrective measures:</p> <ul data-bbox="311 308 969 360" style="list-style-type: none"> <li data-bbox="311 308 969 360">• If this message is displayed again, contact the Service (see Section 8, page 83).
6902	<p data-bbox="314 379 583 411">⚠ QUALIFIED PERSON</p> <p data-bbox="292 427 605 451">DC converter string B defective</p> <p data-bbox="292 464 507 488">Corrective measures:</p> <ul data-bbox="311 499 969 552" style="list-style-type: none"> <li data-bbox="311 499 969 552">• If this message is displayed again, contact the Service (see Section 8, page 83).
7001	<p data-bbox="314 571 583 603">⚠ QUALIFIED PERSON</p> <p data-bbox="292 619 628 643">Fault sensor interior temperature</p> <p data-bbox="292 655 473 679">Measurement error.</p> <p data-bbox="292 692 507 716">Corrective measures:</p> <ul data-bbox="311 727 757 743" style="list-style-type: none"> <li data-bbox="311 727 757 743">• Contact the Service (see Section 8, page 83).
7002	<p data-bbox="314 762 583 794">⚠ QUALIFIED PERSON</p> <p data-bbox="292 810 664 834">Fault sensor power unit temperature</p> <p data-bbox="292 847 473 871">Measurement error.</p> <p data-bbox="292 884 507 908">Corrective measures:</p> <ul data-bbox="311 919 757 935" style="list-style-type: none"> <li data-bbox="311 919 757 935">• Contact the Service (see Section 8, page 83).
7106	<p data-bbox="292 954 479 978">Update file defect.</p> <p data-bbox="292 991 986 1046">The update file is defective. The update failed. The inverter continues to feed in.</p>
7110	<p data-bbox="292 1066 507 1090">No update file found</p> <p data-bbox="292 1102 969 1158">No new update file was found on the SD memory card. The update failed. The inverter continues to feed in.</p>
7112	<p data-bbox="292 1177 605 1201">Update file successfully copied</p>
7113	<p data-bbox="292 1217 720 1241">The memory card is full or write-protected</p>
7201	<p data-bbox="292 1257 524 1281">Data storage defective</p> <p data-bbox="292 1294 507 1318">Corrective measures:</p> <ul data-bbox="311 1329 969 1377" style="list-style-type: none"> <li data-bbox="311 1329 969 1377">• If this message is displayed again, contact the Service (see Section 8, page 83).

Event number	Message, cause and corrective measures
7202	<p>Long term data defective</p> <p>Corrective measures:</p> <ul style="list-style-type: none"> • If this message is displayed again, contact the Service (see Section 8, page 83).
7303	<p>⚠ QUALIFIED PERSON</p> <p>Update main CPU failed</p> <p>The cause must be determined by the Service.</p> <p>Corrective measures:</p> <ul style="list-style-type: none"> • Contact the Service (see Section 8, page 83).
7320	<p>The device with serial number u0 was successfully updated to firmware version u/9/4 .</p>
7324	<p>⚠ QUALIFIED PERSON</p> <p>Wait for update conditions</p> <p>The testing of the update conditions was not successful. The firmware update package is not suitable for this inverter.</p> <p>Corrective measures:</p> <ul style="list-style-type: none"> • Retry update. • Ensure that the selected update file is suitable for this inverter. • If this message is displayed again, contact the Service (see Section 8, page 83).
7330	<p>⚠ QUALIFIED PERSON</p> <p>Condition test failed</p> <p>Corrective measures:</p> <ul style="list-style-type: none"> • Retry update. • Ensure that the selected update file is suitable for this inverter. • If this message is displayed again, contact the Service (see Section 8, page 83).
7331	<p>Update transport started</p> <p>Update file is being copied.</p>
7332	<p>Update transport successful</p> <p>Update file was copied successfully to the inverter's internal memory.</p>

Event number	Message, cause and corrective measures
7333	<p data-bbox="311 188 595 220">⚠ QUALIFIED PERSON</p> <p data-bbox="288 236 533 263">Update transport failed</p> <p data-bbox="288 272 997 355">Update file could not be copied to the inverter's internal memory. In the event of connection with the inverter via WLAN, a poor connection quality can be the cause.</p> <p data-bbox="288 365 508 389">Corrective measures:</p> <ul data-bbox="311 400 969 488" style="list-style-type: none"> <li data-bbox="311 400 460 424">• Retry update. <li data-bbox="311 432 969 488">• If this message is displayed again, contact the Service (see Section 8, page 83).
7337	<p data-bbox="311 507 595 539">⚠ QUALIFIED PERSON</p> <p data-bbox="288 555 869 582">Battery management system update unsuccessful ([d0])</p> <p data-bbox="288 592 508 616">Corrective measures:</p> <ul data-bbox="311 627 969 746" style="list-style-type: none"> <li data-bbox="311 627 460 651">• Retry update. <li data-bbox="311 659 894 683">• Ensure that the selected update file is suitable for this inverter. <li data-bbox="311 691 969 746">• If this message is displayed again, contact the Service (see Section 8, page 83).
7340	<p data-bbox="288 762 594 790">Update communication failed</p>
7347	<p data-bbox="311 802 595 834">⚠ QUALIFIED PERSON</p> <p data-bbox="288 850 463 877">Incompatible file</p> <p data-bbox="288 887 757 914">The configuration file is not suitable for this inverter.</p> <p data-bbox="288 924 508 948">Corrective measures:</p> <ul data-bbox="311 959 950 1018" style="list-style-type: none"> <li data-bbox="311 959 950 983">• Ensure that the selected configuration file is suitable for this inverter. <li data-bbox="311 991 452 1018">• Retry import.
7348	<p data-bbox="311 1042 595 1074">⚠ QUALIFIED PERSON</p> <p data-bbox="288 1090 493 1114">Incorrect file format</p> <p data-bbox="288 1123 885 1150">The configuration file is not of the required format or is damaged.</p> <p data-bbox="288 1160 508 1184">Corrective measures:</p> <ul data-bbox="311 1195 997 1283" style="list-style-type: none"> <li data-bbox="311 1195 997 1246">• Ensure that the selected configuration file is of the required format and is not damaged. <li data-bbox="311 1254 452 1283">• Retry import.
7349	<p data-bbox="288 1297 717 1324">Incorrect login rights for configuration file</p> <p data-bbox="288 1334 656 1361">The configuration file cannot be loaded.</p> <p data-bbox="288 1370 508 1394">Corrective measures:</p> <ul data-bbox="311 1406 932 1452" style="list-style-type: none"> <li data-bbox="311 1406 932 1452">• Make sure you are logged on in the correct user level to load the configuration file.

Event number	Message, cause and corrective measures
7350	<p>Transfer of a configuration file has started The configuration file is being transferred.</p>
7351	<p>Update WLAN The inverter is updating the WLAN module.</p>
7352	<p>⚠ QUALIFIED PERSON</p> <p>Update of WLAN not successful The update of the WLAN module failed.</p> <p>Corrective measures:</p> <ul style="list-style-type: none"> • Retry update. • If this message is displayed again, contact the Service (see Section 8, page 83).
7353	<p>Update time zone database The inverter is updating the time zone database.</p>
7354	<p>⚠ QUALIFIED PERSON</p> <p>Update of time zone database not successful The update of the time zone database failed.</p> <p>Corrective measures:</p> <ul style="list-style-type: none"> • Retry update. • If this message is displayed again, contact the Service (see Section 8, page 83).
7355	<p>Update WebUI The inverter is updating the inverter user interface.</p>
7356	<p>⚠ QUALIFIED PERSON</p> <p>Update of the WebUI not successful The update of the inverter user interface failed.</p> <p>Corrective measures:</p> <ul style="list-style-type: none"> • Retry update. • If this message is displayed again, contact the Service (see Section 8, page 83).
7357	<p>Update BIM The Battery Interface Module on the communication assembly has been successfully updated.</p>

Event number	Message, cause and corrective measures
7358	<p data-bbox="294 183 596 220">⚠ QUALIFIED PERSON</p> <p data-bbox="294 236 481 263">Update BIM failed</p> <p data-bbox="294 271 980 327">The Battery Interface Module on the communication assembly has not been updated successfully.</p> <p data-bbox="294 335 509 359">Corrective measures:</p> <ul data-bbox="311 367 968 454" style="list-style-type: none"> <li data-bbox="311 367 459 391">• Retry update. <li data-bbox="311 399 968 454">• If this message is displayed again, contact the Service (see Section 8, page 83).
7359	<p data-bbox="294 470 420 497">Update BUC</p> <p data-bbox="294 505 957 561">The SMA Backup Unit Controller that is installed in the automatic transfer switch has been updated successfully.</p>
7360	<p data-bbox="294 574 596 611">⚠ QUALIFIED PERSON</p> <p data-bbox="294 627 484 654">Update BUC failed</p> <p data-bbox="294 662 509 686">Corrective measures:</p> <ul data-bbox="311 694 1008 941" style="list-style-type: none"> <li data-bbox="311 694 1008 750">• Ensure that the communication between SMA Backup Unit Controller and the inverter functions perfectly. <li data-bbox="311 758 1008 845">• Ensure that the cable requirements of the communication cable for the communication between the SMA Backup Unit Controller and the inverter have been met. <li data-bbox="311 853 459 877">• Retry update. <li data-bbox="311 885 968 941">• If this message is displayed again, contact the Service (see Section 8, page 83).
7619	<p data-bbox="294 957 596 994">⚠ QUALIFIED PERSON</p> <p data-bbox="294 1010 1002 1037">Communication fault with meter unit > Check communication to meter</p> <p data-bbox="294 1045 840 1069">The inverter is not receiving any data from the energy meter.</p> <p data-bbox="294 1077 509 1101">Corrective measures:</p> <ul data-bbox="311 1109 1008 1165" style="list-style-type: none"> <li data-bbox="311 1109 1008 1165">• Ensure that the energy meter is correctly integrated into the same network as the inverter (see energy meter manual).

Event number	Message, cause and corrective measures
7623	<p data-bbox="311 185 596 220">⚠ QUALIFIED PERSON</p> <p data-bbox="288 236 748 263">Communication to backup module disrupted</p> <p data-bbox="288 272 1001 327">The communication between the inverter and the SMA Backup Unit Controller in the automatic transfer switch is disrupted.</p> <p data-bbox="288 336 508 360">Corrective measures:</p> <ul data-bbox="311 370 1009 611" style="list-style-type: none"> <li data-bbox="311 370 1009 454">• Ensure that the cable requirements of the communication cable for the communication between the SMA Backup Unit Controller and the inverter have been met. <li data-bbox="311 464 460 488">• Retry update. <li data-bbox="311 497 609 521">• Carry out communication test. <li data-bbox="311 531 997 611">• If the communication test was successful, contact the manufacturer of the automatic transfer switch. If the communication test failed, contact the Service (see Section 8, page 83).
7624	<p data-bbox="311 627 596 662">⚠ QUALIFIED PERSON</p> <p data-bbox="288 678 841 705">Communication to battery interface module disrupted</p> <p data-bbox="288 715 993 769">The communication between the inverter and the battery interface module on the communication assembly is disrupted.</p> <p data-bbox="288 778 508 802">Corrective measures:</p> <ul data-bbox="311 812 1001 901" style="list-style-type: none"> <li data-bbox="311 812 1001 836">• Ensure that the ribbon cable is in perfect condition and securely in place. <li data-bbox="311 845 990 901">• If the ribbon cable is in perfect condition and firmly plugged in the jack, contact the Service (see Section 8, page 83).
7701	<p data-bbox="311 914 596 949">⚠ QUALIFIED PERSON</p> <p data-bbox="288 965 544 992">Grid disconnection point</p> <p data-bbox="288 1002 609 1026">Grid relay of the inverter defective.</p> <p data-bbox="288 1035 508 1059">Corrective measures:</p> <ul data-bbox="311 1069 754 1093" style="list-style-type: none"> <li data-bbox="311 1069 754 1093">• Contact the Service (see Section 8, page 83).
7702	<p data-bbox="288 1114 421 1141">Relay defect</p> <p data-bbox="288 1150 609 1174">Grid relay of the inverter defective.</p> <p data-bbox="288 1184 508 1208">Corrective measures:</p> <ul data-bbox="311 1217 754 1241" style="list-style-type: none"> <li data-bbox="311 1217 754 1241">• Contact the Service (see Section 8, page 83).
7703	<p data-bbox="311 1257 596 1292">⚠ QUALIFIED PERSON</p> <p data-bbox="288 1308 434 1335">24h relay test</p> <p data-bbox="288 1345 443 1369">Relay test failed.</p> <p data-bbox="288 1378 508 1402">Corrective measures:</p> <ul data-bbox="311 1412 969 1469" style="list-style-type: none"> <li data-bbox="311 1412 969 1469">• If this message is displayed again, contact the Service (see Section 8, page 83).

Event number	Message, cause and corrective measures
8003	<p data-bbox="311 183 599 215">⚠ QUALIFIED PERSON</p> <p data-bbox="288 231 599 263">Active power limited derating</p> <p data-bbox="288 271 1002 327">The inverter has reduced its power output for more than ten minutes due to excessive temperature.</p> <p data-bbox="288 335 509 359">Corrective measures:</p> <ul data-bbox="311 367 980 550" style="list-style-type: none"> • Clean the cooling fins on the rear of the enclosure and the air ducts on the top using a soft brush. • Ensure that the inverter has sufficient ventilation. • Ensure that the ambient temperature +45 °C (113 °F) has not been exceeded. • Ensure that the inverter is not exposed to direct solar irradiation.
8101	<p data-bbox="311 566 599 598">⚠ QUALIFIED PERSON</p> <p data-bbox="288 614 537 646">Main memory defective</p> <p data-bbox="288 654 509 678">Corrective measures:</p> <ul data-bbox="311 686 968 742" style="list-style-type: none"> • If this message is displayed again, contact the Service (see Section 8, page 83).
8102	<p data-bbox="311 758 599 790">⚠ QUALIFIED PERSON</p> <p data-bbox="288 805 537 837">Code memory defective</p> <p data-bbox="288 845 509 869">Corrective measures:</p> <ul data-bbox="311 877 968 933" style="list-style-type: none"> • If this message is displayed again, contact the Service (see Section 8, page 83).
8103	<p data-bbox="311 949 599 981">⚠ QUALIFIED PERSON</p> <p data-bbox="288 997 453 1029">CPU self-test HP</p> <p data-bbox="288 1037 459 1061">The self-test failed.</p> <p data-bbox="288 1069 509 1093">Corrective measures:</p> <ul data-bbox="311 1101 968 1157" style="list-style-type: none"> • If this message is displayed again, contact the Service (see Section 8, page 83).
8104	<p data-bbox="311 1173 599 1204">⚠ QUALIFIED PERSON</p> <p data-bbox="288 1220 532 1252">Internal communication</p> <p data-bbox="288 1260 509 1284">Corrective measures:</p> <ul data-bbox="311 1292 968 1348" style="list-style-type: none"> • If this message is displayed again, contact the Service (see Section 8, page 83).

Event number	Message, cause and corrective measures
8501	<p data-bbox="314 188 583 220">⚠ QUALIFIED PERSON</p> <p data-bbox="292 236 557 260">DC current sensor C offset</p> <p data-bbox="292 272 507 296">Corrective measures:</p> <ul data-bbox="311 308 969 363" style="list-style-type: none"> <li data-bbox="311 308 969 363">• If this message is displayed again, contact the Service (see Section 8, page 83).
8502	<p data-bbox="314 379 583 411">⚠ QUALIFIED PERSON</p> <p data-bbox="292 427 605 451">DC converter string C defective</p> <p data-bbox="292 464 507 488">Corrective measures:</p> <ul data-bbox="311 499 969 555" style="list-style-type: none"> <li data-bbox="311 499 969 555">• If this message is displayed again, contact the Service (see Section 8, page 83).
8708	<p data-bbox="314 571 583 603">⚠ QUALIFIED PERSON</p> <p data-bbox="292 619 832 643">Timeout in communication for active power limitation</p> <p data-bbox="292 655 1003 735">Communication to the system control absent. Depending on the fall-back setting, either the last received values will be retained or the active power will be limited to the set percentage value of the inverter nominal power.</p> <p data-bbox="292 748 507 772">Corrective measures:</p> <ul data-bbox="311 783 953 839" style="list-style-type: none"> <li data-bbox="311 783 953 839">• Ensure that the connection to the system control is intact and that no cables are damaged or that no plugs have been pulled.
8709	<p data-bbox="314 855 583 887">⚠ QUALIFIED PERSON</p> <p data-bbox="292 903 809 927">Timeout in communication for reactive power spec.</p> <p data-bbox="292 940 1003 1019">Communication to the system control absent. Depending on the fall-back setting, either the last received values will be retained or the active power will be limited to the set percentage value of the inverter nominal power.</p> <p data-bbox="292 1032 507 1056">Corrective measures:</p> <ul data-bbox="311 1067 953 1123" style="list-style-type: none"> <li data-bbox="311 1067 953 1123">• Ensure that the connection to the system control is intact and that no cables are damaged or that no plugs have been pulled.
8710	<p data-bbox="314 1139 583 1171">⚠ QUALIFIED PERSON</p> <p data-bbox="292 1187 726 1211">Timeout in communication for cos-Phi spec.</p> <p data-bbox="292 1224 1003 1303">Communication to the system control absent. Depending on the fall-back setting, either the last received values will be retained or the active power will be limited to the set percentage value of the inverter nominal power.</p> <p data-bbox="292 1316 507 1340">Corrective measures:</p> <ul data-bbox="311 1351 953 1407" style="list-style-type: none"> <li data-bbox="311 1351 953 1407">• Ensure that the connection to the system control is intact and that no cables are damaged or that no plugs have been pulled.

Event number	Message, cause and corrective measures
8801 to 8803	<p>No display</p> <p>No information can be shown on the display.</p>
9002	<p>⚠ QUALIFIED PERSON</p> <p>SMA Grid Guard code invalid</p> <p>The SMA Grid Guard code entered is incorrect. The operating parameters are still protected and cannot be changed.</p> <p>Corrective measures:</p> <ul style="list-style-type: none"> • Enter the correct SMA Grid Guard code.
9003	<p>Grid parameter locked</p> <p>Changes to the grid parameters are now blocked. In order to be able to make changes to the grid parameters, from now on you must log in using the SMA Grid Guard code.</p>
9005	<p>⚠ QUALIFIED PERSON</p> <p>Changing of grid parameters not possible > Ensure DC supply</p> <p>This error can have the following causes:</p> <ul style="list-style-type: none"> • The parameters to be changed are protected. • The DC voltage at the DC input is not sufficient to run the main CPU. <p>Corrective measures:</p> <ul style="list-style-type: none"> • Enter the SMA Grid Guard code. • Ensure that at least the DC start voltage is available (green LED is flashing, pulsing or glowing).
9007	<p>⚠ QUALIFIED PERSON</p> <p>Abort self-test</p> <p>The self-test was terminated.</p> <p>Corrective measures:</p> <ul style="list-style-type: none"> • Restart the self-test.
9202	<p>⚠ QUALIFIED PERSON</p> <p>SPS AC overvoltage</p> <p>An AC source has been connected to the socket connection for secure power supply operation.</p> <p>Corrective measures:</p> <ul style="list-style-type: none"> • Check the connection at the SPS slots, and make any necessary corrections.

Event number	Message, cause and corrective measures
9203	<p data-bbox="311 183 596 215">⚠ QUALIFIED PERSON</p> <p data-bbox="288 231 658 263">Short circuit in the SPS power outlet</p> <p data-bbox="288 271 1014 359">The maximum initial load has been overshoot or the appliance's initial current is above the maximum permissible load current of the connection for secure power supply operation for more than 5 s.</p> <p data-bbox="288 367 509 391">Corrective measures:</p> <ul data-bbox="311 399 980 454" style="list-style-type: none"> • Reduce the load at the connection for secure power supply operation. • If necessary, select an appliance with a lower initial current.
9204	<p data-bbox="311 470 596 502">⚠ QUALIFIED PERSON</p> <p data-bbox="288 518 599 550">AC overvoltage backup (fast)</p> <p data-bbox="288 558 1014 614">Voltage in the battery-backup grid too high or step changes in load too high in the battery-backup grid.</p> <p data-bbox="288 622 509 646">Corrective measures:</p> <ul data-bbox="311 654 1002 782" style="list-style-type: none"> • Check whether there is a new firmware version available for the inverter. • If a newer version is available, perform the firmware update. • If no new firmware version is available, please contact Service (see Section 8, page 83).
9205	<p data-bbox="311 798 596 829">⚠ QUALIFIED PERSON</p> <p data-bbox="288 845 610 877">AC overvoltage backup (slow)</p> <p data-bbox="288 885 1014 941">Voltage in the battery-backup grid too high or step changes in load too high in the battery-backup grid.</p> <p data-bbox="288 949 509 973">Corrective measures:</p> <ul data-bbox="311 981 1002 1109" style="list-style-type: none"> • Check whether there is a new firmware version available for the inverter. • If a newer version is available, perform the firmware update. • If no new firmware version is available, please contact Service (see Section 8, page 83).
9206	<p data-bbox="311 1117 596 1149">⚠ QUALIFIED PERSON</p> <p data-bbox="288 1165 520 1197">Short circuit in backup</p> <p data-bbox="288 1204 677 1236">Loads in the battery-backup grid too high.</p> <p data-bbox="288 1244 509 1268">Corrective measures:</p> <ul data-bbox="311 1276 756 1332" style="list-style-type: none"> • Reduce loads. • Contact the Service (see Section 8, page 83).

Event number	Message, cause and corrective measures
9207	<p>⚠ QUALIFIED PERSON</p> <p>Backup module bimetal switch Automatic transfer switch error.</p> <p>Corrective measures:</p> <ul style="list-style-type: none"> • Contact the automatic transfer switch manufacturer.
9208	<p>⚠ QUALIFIED PERSON</p> <p>Backup module relay error [d0] Relay in the automatic transfer switch faulty.</p> <p>Corrective measures:</p> <ul style="list-style-type: none"> • Contact the automatic transfer switch manufacturer.
9209	<p>⚠ QUALIFIED PERSON</p> <p>N-PE monitoring backup module</p> <p>Corrective measures:</p> <ul style="list-style-type: none"> • Contact the automatic transfer switch manufacturer.
9211	<p>⚠ QUALIFIED PERSON</p> <p>Backup module overtemperature</p> <p>Corrective measures:</p> <ul style="list-style-type: none"> • Check the installation of the automatic transfer switch. • Contact the automatic transfer switch manufacturer.
9214	<p>⚠ QUALIFIED PERSON</p> <p>Black start battery voltage too low The service life of the backup battery has expired. The backup battery must be replaced when you want to use the black start for the battery-backup function or the secure power supply operation.</p> <p>Corrective measures:</p> <ul style="list-style-type: none"> • Procure new backup battery and exchange batteries. • Contact the Service (see Section 8, page 83).
9215	<p>⚠ QUALIFIED PERSON</p> <p>Battery interface module hardware error The battery interface module is defective.</p> <p>Corrective measures:</p> <ul style="list-style-type: none"> • Contact the Service (see Section 8, page 83).

Event number	Message, cause and corrective measures
9216	<p data-bbox="314 188 594 220">⚠ QUALIFIED PERSON</p> <p data-bbox="292 236 530 263">Supply voltage too low</p> <p data-bbox="292 272 508 296">Corrective measures:</p> <ul data-bbox="311 308 972 424" style="list-style-type: none"> <li data-bbox="311 308 972 363">• Check whether the ribbon cable between the inverter and the battery interface module on the communication assembly is correctly inserted. <li data-bbox="311 368 972 424">• If this message is displayed again, contact the Service (see Section 8, page 83).
9217	<p data-bbox="314 443 594 475">⚠ QUALIFIED PERSON</p> <p data-bbox="292 491 1005 547">Output supply voltage of the battery interface module too low [b4] b5 </p> <p data-bbox="292 557 508 580">Corrective measures:</p> <ul data-bbox="311 592 972 708" style="list-style-type: none"> <li data-bbox="311 592 972 647">• Check whether the plugs for connecting the battery and the automatic transfer switch are correctly inserted. <li data-bbox="311 652 972 708">• If this message is displayed again, contact the Service (see Section 8, page 83).
9218	<p data-bbox="314 727 594 759">⚠ QUALIFIED PERSON</p> <p data-bbox="292 775 947 802">Battery interface module output communication error [b4] b5 </p> <p data-bbox="292 812 508 836">Corrective measures:</p> <ul data-bbox="311 847 972 930" style="list-style-type: none"> <li data-bbox="311 847 972 903">• Check whether the plugs for connecting the battery and the automatic transfer switch are correctly inserted. <li data-bbox="311 908 609 930">• Carry out communication test.
9219	<p data-bbox="314 951 594 983">⚠ QUALIFIED PERSON</p> <p data-bbox="292 999 947 1026">Battery interface module output communication error [b4] b5 </p> <p data-bbox="292 1035 508 1059">Corrective measures:</p> <ul data-bbox="311 1070 972 1153" style="list-style-type: none"> <li data-bbox="311 1070 972 1153">• Make sure that only one node each is connected to the connections for the communication cables of the battery and the automatic transfer switch.
9220	<p data-bbox="292 1171 701 1198">Battery interface module test mode [s0]</p> <p data-bbox="292 1203 647 1230">The communication test was successful.</p>
9221	<p data-bbox="314 1246 594 1278">⚠ QUALIFIED PERSON</p> <p data-bbox="292 1294 1005 1350">Limitation of the switching frequency of the input relay for current limitation</p> <p data-bbox="292 1359 902 1386">There are too many faulty control commands by the system control.</p> <p data-bbox="292 1396 508 1420">Corrective measures:</p> <ul data-bbox="311 1431 535 1455" style="list-style-type: none"> <li data-bbox="311 1431 535 1455">• Check system control.

Event number	Message, cause and corrective measures
9223	<p>Backup operation</p> <p>The battery-backup function is enabled.</p>
9301	<p>New battery detected</p>
9303	<p>⚠ QUALIFIED PERSON</p> <p>The service life of the battery is expiring</p> <p>The battery can fail anytime.</p> <p>Corrective measures:</p> <ul style="list-style-type: none"> • Procure new battery and exchange batteries.
9304	<p>⚠ QUALIFIED PERSON</p> <p>Battery connection fault</p> <p>Corrective measures:</p> <ul style="list-style-type: none"> • Check the connection for the data cable of the battery. • Carry out communication test.
9305	<p>⚠ QUALIFIED PERSON</p> <p>Unauthorized battery system</p> <p>Corrective measures:</p> <ul style="list-style-type: none"> • Check whether there is a new firmware version available for the battery. If a newer version is available, perform the firmware update. • If this message is displayed again, contact the Service (see Section 8, page 83).
9306	<p>⚠ QUALIFIED PERSON</p> <p>Deviation in battery voltage</p> <p>Corrective measures:</p> <ul style="list-style-type: none"> • Check the DC connection. • If this message is displayed again, contact the Service (see Section 8, page 83).
9307	<p>⚠ QUALIFIED PERSON</p> <p>Battery system defective</p> <p>Corrective measures:</p> <ul style="list-style-type: none"> • Contact the battery manufacturer.

Event number	Message, cause and corrective measures
9308	<p data-bbox="314 188 591 220">⚠ QUALIFIED PERSON</p> <p data-bbox="292 236 667 263">Communication error battery system</p> <p data-bbox="292 272 508 296">Corrective measures:</p> <ul data-bbox="311 308 978 392" style="list-style-type: none"> <li data-bbox="311 308 978 392">• Carry out communication test. If the test was successful, contact the battery manufacturer. If the test was not successful, contact the Service (see Section 8, page 83).
9311	<p data-bbox="314 408 591 440">⚠ QUALIFIED PERSON</p> <p data-bbox="292 456 589 483">Battery cell overvoltage fault</p> <p data-bbox="292 493 508 517">Corrective measures:</p> <ul data-bbox="311 528 645 552" style="list-style-type: none"> <li data-bbox="311 528 645 552">• Contact the battery manufacturer.
9312	<p data-bbox="314 568 591 600">⚠ QUALIFIED PERSON</p> <p data-bbox="292 616 602 643">Battery cell undervoltage fault</p> <p data-bbox="292 652 508 676">Corrective measures:</p> <ul data-bbox="311 687 645 711" style="list-style-type: none"> <li data-bbox="311 687 645 711">• Contact the battery manufacturer.
9313	<p data-bbox="314 727 591 759">⚠ QUALIFIED PERSON</p> <p data-bbox="292 775 595 802">Battery low temperature fault</p> <p data-bbox="292 812 508 836">Corrective measures:</p> <ul data-bbox="311 847 645 871" style="list-style-type: none"> <li data-bbox="311 847 645 871">• Contact the battery manufacturer.
9314	<p data-bbox="314 887 591 919">⚠ QUALIFIED PERSON</p> <p data-bbox="292 935 546 962">Battery overtemperature</p> <p data-bbox="292 971 508 995">Corrective measures:</p> <ul data-bbox="311 1007 645 1031" style="list-style-type: none"> <li data-bbox="311 1007 645 1031">• Contact the battery manufacturer.
9315	<p data-bbox="314 1046 591 1078">⚠ QUALIFIED PERSON</p> <p data-bbox="292 1094 553 1121">Battery imbalancing fault</p> <p data-bbox="292 1131 508 1155">Corrective measures:</p> <ul data-bbox="311 1166 645 1190" style="list-style-type: none"> <li data-bbox="311 1166 645 1190">• Contact the battery manufacturer.
9316	<p data-bbox="314 1206 591 1238">⚠ QUALIFIED PERSON</p> <p data-bbox="292 1254 613 1281">Internal battery hardware fault</p> <p data-bbox="292 1291 508 1315">Corrective measures:</p> <ul data-bbox="311 1326 645 1350" style="list-style-type: none"> <li data-bbox="311 1326 645 1350">• Contact the battery manufacturer.
9334	<p data-bbox="292 1366 508 1393">Battery charging test</p> <p data-bbox="292 1402 781 1439">The battery test for charging the battery is carried out.</p>

Event number	Message, cause and corrective measures
9335	<p>Discharge battery test</p> <p>The battery test for discharging the battery is carried out.</p>
9336	<p>⚠ QUALIFIED PERSON</p> <p>Start conditions for battery test not fulfilled</p> <p>The state of charge of the battery is too low or too high for carrying out the test.</p> <p>Corrective measures:</p> <ul style="list-style-type: none"> • Perform the test that has not been performed yet.
9337	<p>Charge battery test successful</p>
9338	<p>Battery discharging test successful</p>
9339	<p>⚠ QUALIFIED PERSON</p> <p>Battery charging test failed</p> <p>Corrective measures:</p> <ul style="list-style-type: none"> • Check the installation of the battery. • Perform the test that has not been performed yet.
9340	<p>⚠ QUALIFIED PERSON</p> <p>Battery discharging test failed</p> <p>Corrective measures:</p> <ul style="list-style-type: none"> • Check the installation of the battery. • Perform the test that has not been performed yet.
9345	<p>⚠ QUALIFIED PERSON</p> <p>Battery charging for start process too low</p> <p>Corrective measures:</p> <ul style="list-style-type: none"> • Contact the battery manufacturer.
9346	<p>⚠ QUALIFIED PERSON</p> <p>Battery not configured</p> <p>Corrective measures:</p> <ul style="list-style-type: none"> • Start the installation assistant on the inverter user interface and perform the battery configuration.

Event number	Message, cause and corrective measures
9347	<p data-bbox="314 188 594 220">⚠ QUALIFIED PERSON</p> <p data-bbox="292 236 997 292">Battery b0 reports event: 0x x5 x4 , 0x x7 x6 , 0x x9 x8 , 0x xB xA </p> <p data-bbox="292 304 507 328">Corrective measures:</p> <ul data-bbox="311 336 642 360" style="list-style-type: none"> • Contact the battery manufacturer.
9351	<p data-bbox="314 379 594 411">⚠ QUALIFIED PERSON</p> <p data-bbox="292 427 897 451">Incorrect switch position for the battery disconnection point</p> <p data-bbox="292 464 507 488">Corrective measures:</p> <ul data-bbox="311 496 642 520" style="list-style-type: none"> • Contact the battery manufacturer.
9352	<p data-bbox="314 539 594 571">⚠ QUALIFIED PERSON</p> <p data-bbox="292 587 566 611">Battery system short circuit</p> <p data-bbox="292 624 507 647">Corrective measures:</p> <ul data-bbox="311 655 642 679" style="list-style-type: none"> • Contact the battery manufacturer.
9353	<p data-bbox="314 699 594 730">⚠ QUALIFIED PERSON</p> <p data-bbox="292 746 768 770">Battery system thermal management defective</p> <p data-bbox="292 783 507 807">Corrective measures:</p> <ul data-bbox="311 815 997 911" style="list-style-type: none"> • Check whether there is a new firmware version available for the battery. If a newer version is available, perform the firmware update. • If this message is displayed again, contact the battery manufacturer.
9354	<p data-bbox="314 927 594 959">⚠ QUALIFIED PERSON</p> <p data-bbox="292 975 768 999">Battery system heating procedure unsuccessful</p> <p data-bbox="292 1011 507 1035">Corrective measures:</p> <ul data-bbox="311 1043 997 1139" style="list-style-type: none"> • Check whether there is a new firmware version available for the battery. If a newer version is available, perform the firmware update. • If this message is displayed again, contact the battery manufacturer.
10100	Parameter [ln04] set successfully. lv04c to lv048
10101	<p data-bbox="292 1189 846 1212">Setting of parameter ln04 failed. lv04c to lv048 </p> <p data-bbox="292 1225 507 1249">Corrective measures:</p> <ul data-bbox="311 1257 740 1289" style="list-style-type: none"> • Change parameter again and save change.
10102	Parameter [ln04] set successfully. tnc to tn8
10103	<p data-bbox="292 1339 796 1362">Setting of parameter ln04 failed. tnc to tn8 </p> <p data-bbox="292 1375 507 1399">Corrective measures:</p> <ul data-bbox="311 1407 740 1441" style="list-style-type: none"> • Change parameter again and save change.

Event number	Message, cause and corrective measures
10104	Parameter [ln04] set successfully
10105	Setting of parameter ln04 failed. Corrective measures: <ul style="list-style-type: none"> • Change parameter again and save change.
10108	Time adjusted / old time
10109	Time adjusted / new time
10110	Time synchronization failed: [x] No time information could be called up from the set NTP server. Corrective measures: <ul style="list-style-type: none"> • Ensure that the NTP server was configured correctly. • Ensure that the inverter is integrated into a local network with Internet connection.
10116	Setting of parameter ln04 failed. Conflict with parameter ln8c
10118	Parameter upload complete
10120	Currently permitted number of parameterizations exceeded
10224	Dynamic settings established
10248	[tn4]: network busy The network is busy. Data exchange between the devices is not at an optimum and is greatly delayed. Corrective measures: <ul style="list-style-type: none"> • Reduce the number of devices in the network. • If necessary, increase the data query intervals. • If necessary, reduce the number of devices in the network.
10249	⚠ QUALIFIED PERSON [tn4]: network overloaded The network is busy. Data exchange between the devices is not at an optimum and is greatly delayed. Corrective measures: <ul style="list-style-type: none"> • Reduce the number of devices in the network. • If necessary, increase the data query intervals. • If necessary, reduce the number of devices in the network.

Event number	Message, cause and corrective measures
10250	<p data-bbox="308 183 593 215">⚠ QUALIFIED PERSON</p> <p data-bbox="285 231 722 263">[Interface]: package error rate [ok / high]</p> <p data-bbox="285 271 1008 359">The package error rate has changed. If the package error rate is high, the network is overloaded or the connection to the network switch or DHCP server (router) is disturbed.</p> <p data-bbox="285 359 834 391">Corrective measures if the package error rate is high:</p> <ul data-bbox="308 399 1008 550" style="list-style-type: none"> • Ensure that with an Ethernet connection, the network cable and the network connector are not damaged and that the network connectors are correctly plugged. • If necessary, increase the data query intervals. • If necessary, reduce the number of devices in the network.
10251	<p data-bbox="285 558 968 622">[Interface]: communication status goes to [OK / Warning / Error / Not connected]</p> <p data-bbox="285 630 985 686">The communication status to the network switch or DHCP server (router) has changed. An additional error message may be displayed.</p>
10252	<p data-bbox="308 694 593 726">⚠ QUALIFIED PERSON</p> <p data-bbox="285 742 672 774">[Interface]: communication disrupted</p> <p data-bbox="285 782 688 813">There is no valid signal on the network line.</p> <p data-bbox="285 813 509 845">Corrective measures:</p> <ul data-bbox="308 853 1008 1005" style="list-style-type: none"> • Ensure that with an Ethernet connection, the network cable and the network connector are not damaged and that the network connectors are correctly plugged. • Ensure that the DHCP server (router) and any network switches are signaling correct operation.
10253	<p data-bbox="308 1013 593 1045">⚠ QUALIFIED PERSON</p> <p data-bbox="285 1061 890 1093">[Interface]: connection speed goes to [100 Mbit / 10 Mbit]</p> <p data-bbox="285 1101 1008 1189">The data transfer rate has changed. The cause for the status [10 Mbit] can be a defective plug, a defective cable or the pulling or plugging of the network connector.</p> <p data-bbox="285 1189 756 1220">Corrective measures if the status is [10 Mbit]:</p> <ul data-bbox="308 1228 1008 1380" style="list-style-type: none"> • Ensure that with an Ethernet connection, the network cable and the network connector are not damaged and that the network connectors are correctly plugged. • Ensure that the DHCP server (router) and any network switches are signaling correct operation.

Event number	Message, cause and corrective measures
10254	<p>⚠ QUALIFIED PERSON</p> <p>[Interface]: duplex mode goes to [Full / Half]</p> <p>The duplex mode (data transfer mode) has changed. The cause for the status [Half] can be a defective plug, a defective cable or the pulling or plugging of the network connector.</p> <p>Corrective measures if the status is [Half]:</p> <ul style="list-style-type: none"> • Ensure that with an Ethernet connection, the network cable and the network connector are not damaged and that the network connectors are correctly plugged. • Ensure that the DHCP server (router) and any network switches are signaling correct operation.
10255	<p>[Interface]: Network load OK</p> <p>The network load has returned to a normal range after being busy.</p>
10282	<p>[User group]-Login via [protocol] locked</p> <p>After several incorrect login attempts, login has been blocked for a limited time. In this case, the User login will be blocked for 15 minutes, the Grid Guard login for 12 hours.</p> <p>Corrective measures:</p> <ul style="list-style-type: none"> • Wait until the given time has expired and then retry login.
10283	<p>WLAN module faulty</p> <p>The WLAN module integrated in the inverter is defective.</p> <p>Corrective measures:</p> <ul style="list-style-type: none"> • Contact the Service (see Section 8, page 83).
10284	<p>⚠ QUALIFIED PERSON</p> <p>No WLAN connection possible</p> <p>The inverter does not currently have a WLAN connection to the selected network.</p> <p>Corrective measures:</p> <ul style="list-style-type: none"> • Ensure that the SSID, the WLAN password and the encryption method have been entered correctly. The encryption method is specified by your WLAN router or WLAN Access Point and can be changed there. • Ensure that the WLAN router or WLAN Access Point is in range and is signaling correct operation. • If this message is displayed often, improve the WLAN connection by using a WLAN repeater (e.g. SMA Antenna Extension Kit).
10285	<p>WLAN connection established</p> <p>Connection to the selected WLAN network has been established.</p>

Event number	Message, cause and corrective measures
10286	<p data-bbox="308 183 593 215">⚠ QUALIFIED PERSON</p> <p data-bbox="285 231 520 263">WLAN connection lost</p> <p data-bbox="285 271 868 295">The inverter has lost WLAN connection to the selected network.</p> <p data-bbox="285 303 509 327">Corrective measures:</p> <ul data-bbox="308 335 980 486" style="list-style-type: none"> • Ensure that the WLAN router or WLAN Access Point is still active. • Ensure that the WLAN router or WLAN Access Point is in range and is signalizing correct operation. • If this message is displayed often, improve the WLAN connection by using a WLAN repeater (e.g. SMA Antenna Extension Kit).
10287	<p data-bbox="285 502 537 534">WLAN module detected</p>
10339	<p data-bbox="285 542 509 574">Webconnect enabled</p> <p data-bbox="285 582 980 638">The inverter can communicate with Sunny Portal without an additional SMA communications product (e.g. Cluster Controller).</p>
10340	<p data-bbox="285 646 515 678">Webconnect disabled</p> <p data-bbox="285 686 996 774">The Webconnect function has been switched off. This means that the inverter can not communicate with Sunny Portal without an additional SMA communications product (e.g. Cluster Controller).</p> <ul data-bbox="308 782 991 837" style="list-style-type: none"> • If the inverter is to communicate with Sunny Portal without an additional SMA communication product, switch the Webconnect function on.
10341	<p data-bbox="285 845 632 877">Webconnect error: no connection</p> <p data-bbox="285 885 778 909">It is likely that there is an error in the network settings.</p> <p data-bbox="285 917 509 941">Corrective measures:</p> <ul data-bbox="308 949 935 1149" style="list-style-type: none"> • Check the network components (DLAN, WLAN Access Point etc.). • Ensure that the following ports are not blocked: <ul data-bbox="352 1021 632 1149" style="list-style-type: none"> - Registrar: ied.sma.de:9523 - Proxy: ied.sma.de:9523 - Stun: stun.sma.de:3478 - Domain: ied.sma.de (for SIP URI)
10343	<p data-bbox="285 1165 817 1197">Webconnect error: Default gateway not configured</p> <p data-bbox="285 1204 778 1228">It is likely that there is an error in the network settings.</p> <p data-bbox="285 1236 509 1260">Corrective measures:</p> <ul data-bbox="308 1268 935 1468" style="list-style-type: none"> • Check the network components (DLAN, WLAN Access Point etc.). • Ensure that the following ports are not blocked: <ul data-bbox="352 1340 632 1468" style="list-style-type: none"> - Registrar: ied.sma.de:9523 - Proxy: ied.sma.de:9523 - Stun: stun.sma.de:3478 - Domain: ied.sma.de (for SIP URI)

Event number	Message, cause and corrective measures
10344	<p>Webconnect error: DNS server not configured</p> <p>It is likely that there is an error in the network settings.</p> <p>Corrective measures:</p> <ul style="list-style-type: none"> • Check the network components (DLAN, WLAN Access Point etc.). • Ensure that the following ports are not blocked: <ul style="list-style-type: none"> - Registrar: ied.sma.de:9523 - Proxy: ied.sma.de:9523 - Stun: stun.sma.de:3478 - Domain: ied.sma.de (for SIP URI)
10345	<p>No reply to DNS request</p> <p>It is likely that there is an error in the network settings.</p> <p>Corrective measures:</p> <ul style="list-style-type: none"> • Check the network components (DLAN, WLAN Access Point etc.). • Ensure that the following ports are not blocked: <ul style="list-style-type: none"> - Registrar: ied.sma.de:9523 - Proxy: ied.sma.de:9523 - Stun: stun.sma.de:3478 - Domain: ied.sma.de (for SIP URI)
10346	<p>SIP proxy DNS resolution failed</p> <p>It is likely that there is an error in the network settings.</p> <p>Corrective measures:</p> <ul style="list-style-type: none"> • Check the network components (DLAN, WLAN Access Point etc.). • Ensure that the following ports are not blocked: <ul style="list-style-type: none"> - Registrar: ied.sma.de:9523 - Proxy: ied.sma.de:9523 - Stun: stun.sma.de:3478 - Domain: ied.sma.de (for SIP URI)
10347	<p>Stun server DNS resolution failed</p> <p>It is likely that there is an error in the network settings.</p> <p>Corrective measures:</p> <ul style="list-style-type: none"> • Check the network components (DLAN, WLAN Access Point etc.). • Ensure that the following ports are not blocked: <ul style="list-style-type: none"> - Registrar: ied.sma.de:9523 - Proxy: ied.sma.de:9523 - Stun: stun.sma.de:3478 - Domain: ied.sma.de (for SIP URI)

Event number	Message, cause and corrective measures
10348	<p>Webconnect error: No reply to request to STUN server</p> <p>It is likely that there is an error in the network settings.</p> <p>Corrective measures:</p> <ul style="list-style-type: none"> • Check the network components (DLAN, WLAN Access Point etc.). • Ensure that the following ports are not blocked: <ul style="list-style-type: none"> - Registrar: ied.sma.de:9523 - Proxy: ied.sma.de:9523 - Stun: stun.sma.de:3478 - Domain: ied.sma.de (for SIP URI)
10349	<p>Webconnect error: No reply to SIP option packs</p> <p>It is likely that there is an error in the network settings or a Sunny Portal maintenance message is present.</p> <p>Corrective measures:</p> <ul style="list-style-type: none"> • If a Sunny Portal maintenance message is present, wait until the maintenance has been completed. • Check the network components (DLAN, WLAN Access Point etc.). • Ensure that the following ports are not blocked: <ul style="list-style-type: none"> - Registrar: ied.sma.de:9523 - Proxy: ied.sma.de:9523 - Stun: stun.sma.de:3478 - Domain: ied.sma.de (for SIP URI)
10350	<p>Webconnect error: Registration rejected by SIP registrar</p> <p>It is likely that there is an error in the network settings.</p> <p>Corrective measures:</p> <ul style="list-style-type: none"> • Check the network components (DLAN, WLAN Access Point etc.). • Ensure that the following ports are not blocked: <ul style="list-style-type: none"> - Registrar: ied.sma.de:9523 - Proxy: ied.sma.de:9523 - Stun: stun.sma.de:3478 - Domain: ied.sma.de (for SIP URI)

Event number	Message, cause and corrective measures
10351	<p>Unknown SIP registry</p> <p>It is likely that there is an error in the network settings.</p> <p>Corrective measures:</p> <ul style="list-style-type: none"> • Check the network components (DLAN, WLAN Access Point etc.). • Ensure that the following ports are not blocked: <ul style="list-style-type: none"> - Registrar: ied.sma.de:9523 - Proxy: ied.sma.de:9523 - Stun: stun.sma.de:3478 - Domain: ied.sma.de (for SIP URI)
10352	<p>Webconnect error: Faulty communication</p> <p>It is likely that there is an error in the network settings or a Sunny Portal maintenance message is present.</p> <p>Corrective measures:</p> <ul style="list-style-type: none"> • If a Sunny Portal maintenance message is present, wait until the maintenance has been completed. • Check the network components (DLAN, WLAN Access Point etc.). • Ensure that the following ports are not blocked: <ul style="list-style-type: none"> - Registrar: ied.sma.de:9523 - Proxy: ied.sma.de:9523 - Stun: stun.sma.de:3478 - Domain: ied.sma.de (for SIP URI)
10353	<p>Webconnect error: registration of the SIP registry has not responded</p> <p>It is likely that there is an error in the network settings or a Sunny Portal maintenance message is present.</p> <p>Corrective measures:</p> <ul style="list-style-type: none"> • If a Sunny Portal maintenance message is present, wait until the maintenance has been completed. • Check the network components (DLAN, WLAN Access Point etc.). • Ensure that the following ports are not blocked: <ul style="list-style-type: none"> - Registrar: ied.sma.de:9523 - Proxy: ied.sma.de:9523 - Stun: stun.sma.de:3478 - Domain: ied.sma.de (for SIP URI)
10420	Internal consumption control was started
10421	Internal consumption control was stopped
10513	NSS quick stop: [tn0] through [tn4] is executed
10517	Dynamic active power limitation started.

Event number	Message, cause and corrective measures
10518	Dynamic active power limitation terminated.
10520	Supplied power: [u0] W (permitted value: [u4] W)
10521	Active power was limited today for [u0] minutes.
10525	Inverter does not respond to active power limitation.
10528	Login for NSD function on device [s0] failed
27107	Update file OK The update file is suitable for this inverter and its components and is fully available for the next update step.
27108	Memory card is being read The storage medium is being read.
27109	No new update on the memory card A new update file was not found on the storage medium.
27301	Update communication The inverter is updating the communication component.
27302	Update main CPU The inverter is updating the inverter component.
27312	Update completed The inverter has successfully completed the update.
27329	Condition test successful
27331	Update transport started The inverter has successfully started the update.
27332	Update transport successful The update file has been successfully transferred to the communication component.
27336	Battery management system
29001	Inst. code valid The entered Grid Guard code is valid. Protected parameters have now been unlocked and you can adjust the parameters. The parameters will be automatically locked again after ten feed-in hours.
29004	Grid parameters unchanged Changing the grid parameters is not possible.
29006	Self-test
29016	Stand-alone operation

Event number	Message, cause and corrective measures
29252	SPS mode not available The battery's state of charge is insufficient to supply the loads in secure power supply operation.
29253	Input power for backup too low The battery's state of charge is insufficient to supply the loads in the battery-backup grid.
29254	Input power for SPS too low The battery's state of charge is insufficient to supply the loads in secure power supply operation.

7 Compliance Information

FCC Compliance

This device complies with Part 15 of the FCC Rules and with Industry Canada licence-exempt RSS standard(s).

Operation is subject to the following two conditions:

1. this device may not cause harmful interference, and
2. this device must accept any interference received, including interference that may cause undesired operation.

Le présent appareil est conforme aux CNR d'Industrie Canada applicables aux appareils radio exempts de licence.

L'exploitation est autorisée aux deux conditions suivantes :

1. l'appareil ne doit pas produire de brouillage, et
2. l'utilisateur de l'appareil doit accepter tout brouillage radioélectrique subi, même si le brouillage est susceptible d'en compromettre le fonctionnement.

NOTE: This equipment has been tested and found to comply with the limits for a Class B digital device, pursuant to Part 15 of the FCC Rules. These limits are designed to provide reasonable protection against harmful interference in a residential installation. This equipment generates, uses and can radiate radio frequency energy and, if not installed and used in accordance with the instructions, may cause harmful interference to radio communications. However, there is no guarantee that interference will not occur in a particular installation. If this equipment does cause harmful interference to radio or television reception, which can be determined by turning the equipment off and on, the user is encouraged to try to correct the interference by one or more of the following measures:

- Reorient or relocate the receiving antenna.
- Increase the separation between the equipment and receiver.
- Connect the equipment into an outlet on a circuit different from that to which the receiver is connected.
- Consult the dealer or an experienced radio/TV technician for help.

Changes or modifications made to this equipment not expressly approved by SMA Solar Technology America LLC may void the FCC authorization to operate this equipment.

8 Contact

If you have technical problems with our products, please contact the SMA Service Line. The following data is required in order to provide you with the necessary assistance:

- Battery inverter:
 - Device type
 - Serial number
 - Firmware version
 - Event message
 - Mounting location and mounting height
 - Optional equipment, e.g. communication products
 - Use the name of the system in Sunny Portal (if available)
 - Access data for Sunny Portal (if available)
 - Special country-specific settings (if available)
- Batteries:
 - Type
 - Firmware version
 - Type of automatic transfer switch (if available)

United States	SMA Solar Technology America LLC Rocklin, CA	Toll free for USA and US Territories +1 877-MY-SMATech (+1 877-697-6283) International: +1 916 625-0870
Canada	SMA Solar Technology Canada Inc. Mississauga	Toll free for Canada / Sans frais pour le Canada : +1 877-MY-SMATech (+1 877-697-6283)
México	SMA Solar Technology de México Mexico City	Internacional: +1 916 625-0870

